

Standard
Architectural Performance Louvres
Designers and Specifiers Technical Manual

Zefyr Group

Top Barn Business Centre, Holt Heath,
Worcestershire, United Kingdom,

WR6 6NH

Tel (+44) 0870 6001356 Fax (+44) 0870 6001357

Standard 60 Continuous Louvre

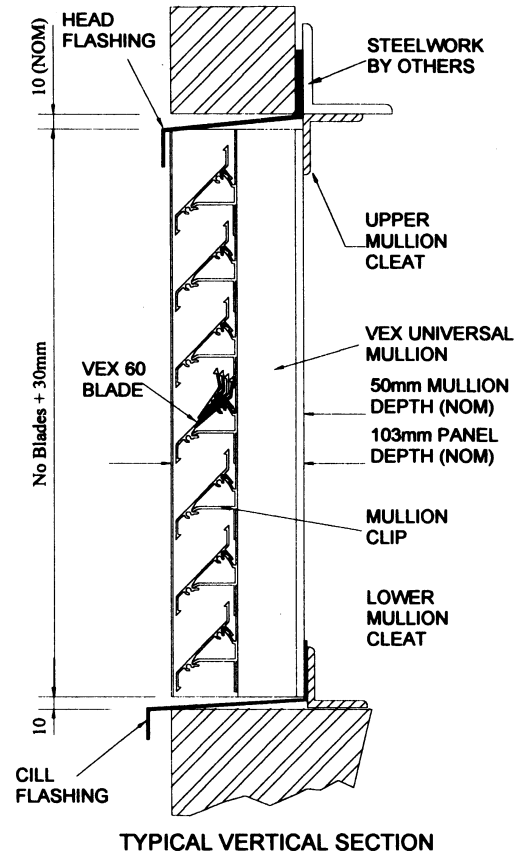
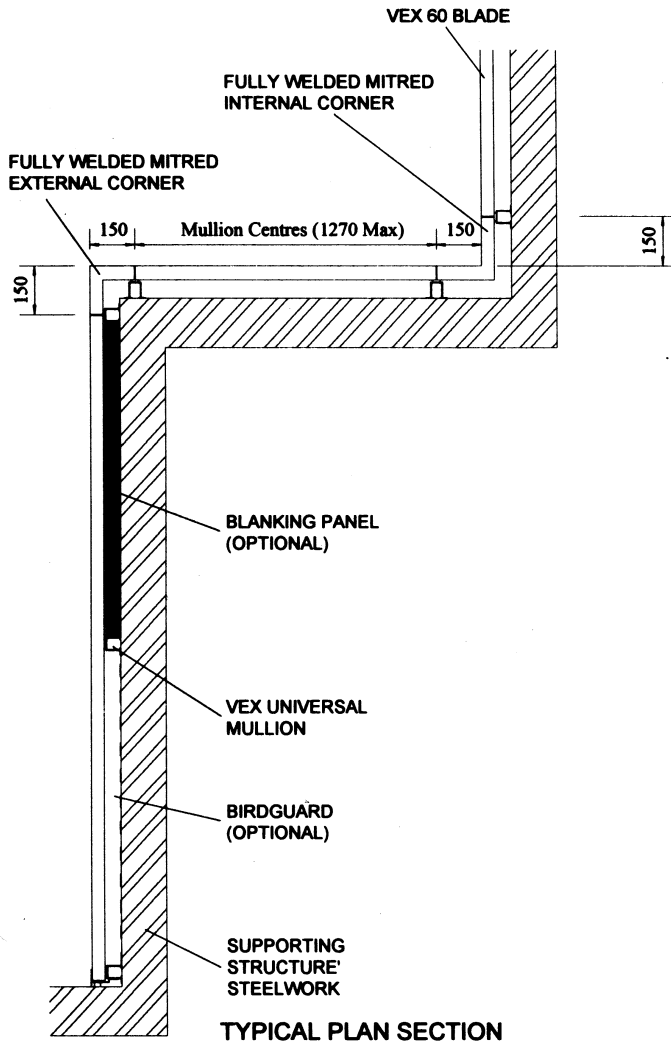

General

Fully tested louvre system - Structurally / Weatherability / Aerodynamically

Blades

Extruded aluminium HE9TF, vertical pitch 60mm with integral aluminium clip system.

Mullions

Mullions can either be constructed from extruded aluminium (HE9TF) or press-formed 2.0mm thick aluminium sheet metal. Factory fitted with durable aluminium "snap on" clips.

Flashings

Flashings are constructed from aluminium sheet 1.5mm / 2.0mm / 3.0mm thick.

Birdguard

Expanded aluminium mesh (flattened) supplied in sheets with fixings for site installation.

Insect Mesh

Fine woven aluminium mesh supplied in rolls with fixings for site installation.

Blanking Panels

Aluminium sheet 1.0mm / 1.5mm / 2.0mm thick. Composite insulated panels available to suit specific thermal requirements

Corners

Internal/External corner blades fully welded or cleated to suit corner angle.

Cleats

Standard range of fixing cleats supplied to suit individual installations.

Site Fixings

Fixings can be supplied to suit individual installations if required.

Steelwork

Secondary steelwork systems are available if required, designed to suit individual applications.

Finish

Options - Mill finished aluminium - Polyester powder coated to a comprehensive range of colours - Anodised AA5 / AA25 Natural / Coloured.

Free Area

48% geometric free area through the blades.

Performance

Refer to 'Pressure Drop' and 'Weatherability' Performance Data Sheets.

Weight

11.45 Kg/m² (nom) face area when with standard Universal Mullion.

Zefyr Group

Top Barn Business Centre, Holt Heath, Worcestershire, WR6 6NH, UK. Tel +44 (0)870 600 1356 Fax +44 (0)870 600 1357

E-mail mail@zefyrgroup.com website www.zefyrgroup.com

Standard 60 Continuous Double Pass Louvre

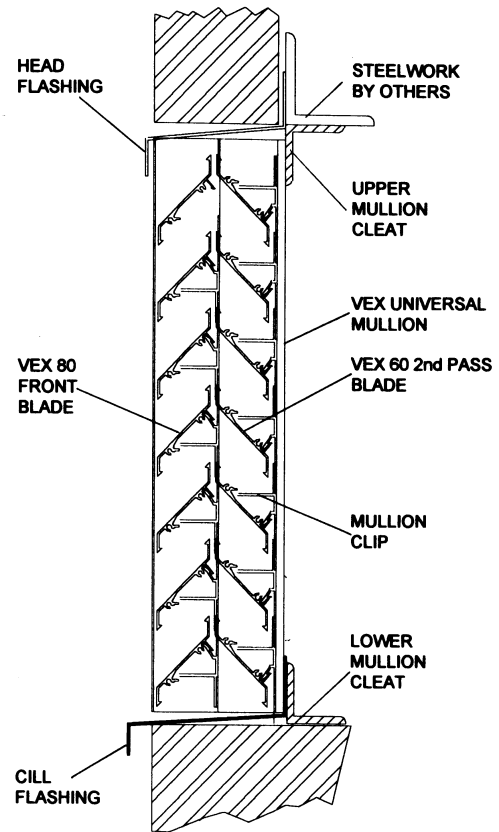
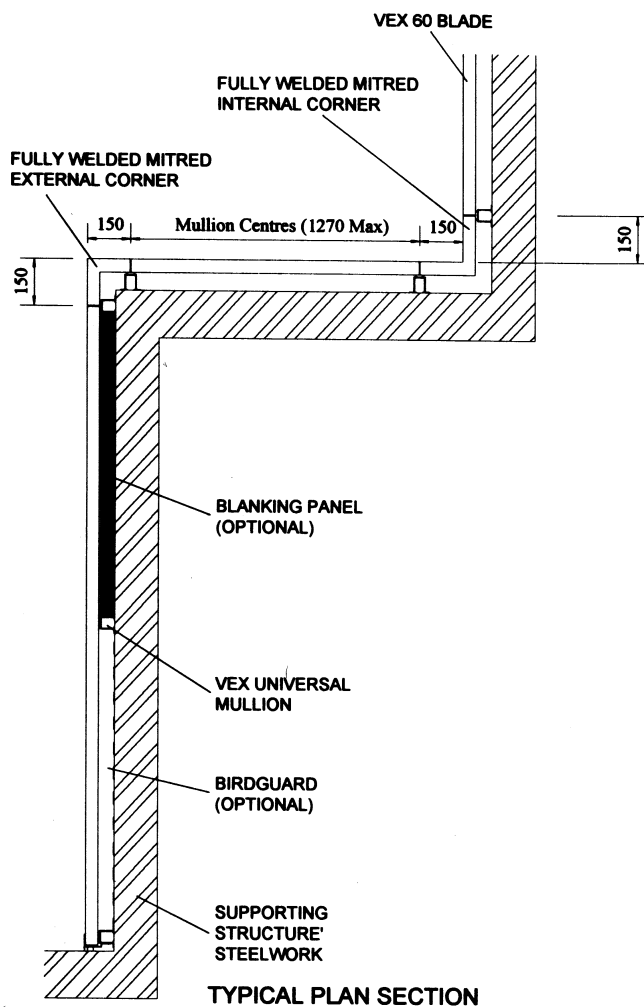

TYPICAL VERTICAL SECTION

General

High performance fully tested louvre system - Structurally / Weatherability / Aerodynamically

Blades

Extruded aluminium HE9TF, vertical pitch 60mm with integral aluminium clip system. Site assembled double pass configuration.

Mullions

Mullions can either be constructed from extruded aluminium (HE9TF) or press-formed 2mm thick aluminium sheet metal. Factory fitted with durable aluminium "snap on" clips.

Flashings

Flashings are constructed from aluminium sheet 1.5mm / 2.0mm / 3.0mm thick.

Birdguard

Expanded aluminium mesh (flattened) supplied in sheets with fixings for site installation.

Insect Mesh

Fine woven aluminium mesh supplied in rolls with fixings for site installation.

Blanking Panels

Aluminium sheet 1.0mm / 1.5mm / 2.0mm thick. Composite insulated panels available to suit specific thermal requirements.

Corners

Internal/External corner blades fully welded or cleated to suit corner angle.

Cleats

Standard range of fixing cleats supplied to suit individual installations.

Site Fixings

Fixings can be supplied to suit individual installations if required.

Steelwork

Secondary steelwork systems are available if required, designed to suit individual applications.

Finish

Options - Mill finished aluminium - Polyester powder coated to a comprehensive range of colours - Anodised AA5 / AA25 Natural / Coloured.

Free Area

48% geometric free area through the blades.

Performance

Refer to 'Pressure Drop' and 'Weatherability' Performance Data Sheets.

Weight

21.12 Kg/m² (nom) face area when with standard Universal Mullion.

Zefyr Group

Top Barn Business Centre, Holt Heath, Worcestershire, WR6 6NH, UK. Tel +44 (0)870 600 1356 Fax +44 (0)870 600 1357

E-mail mail@zefyrgroup.com website www.zefyrgroup.com

Standard 60 Continuous Triple Pass Louvre

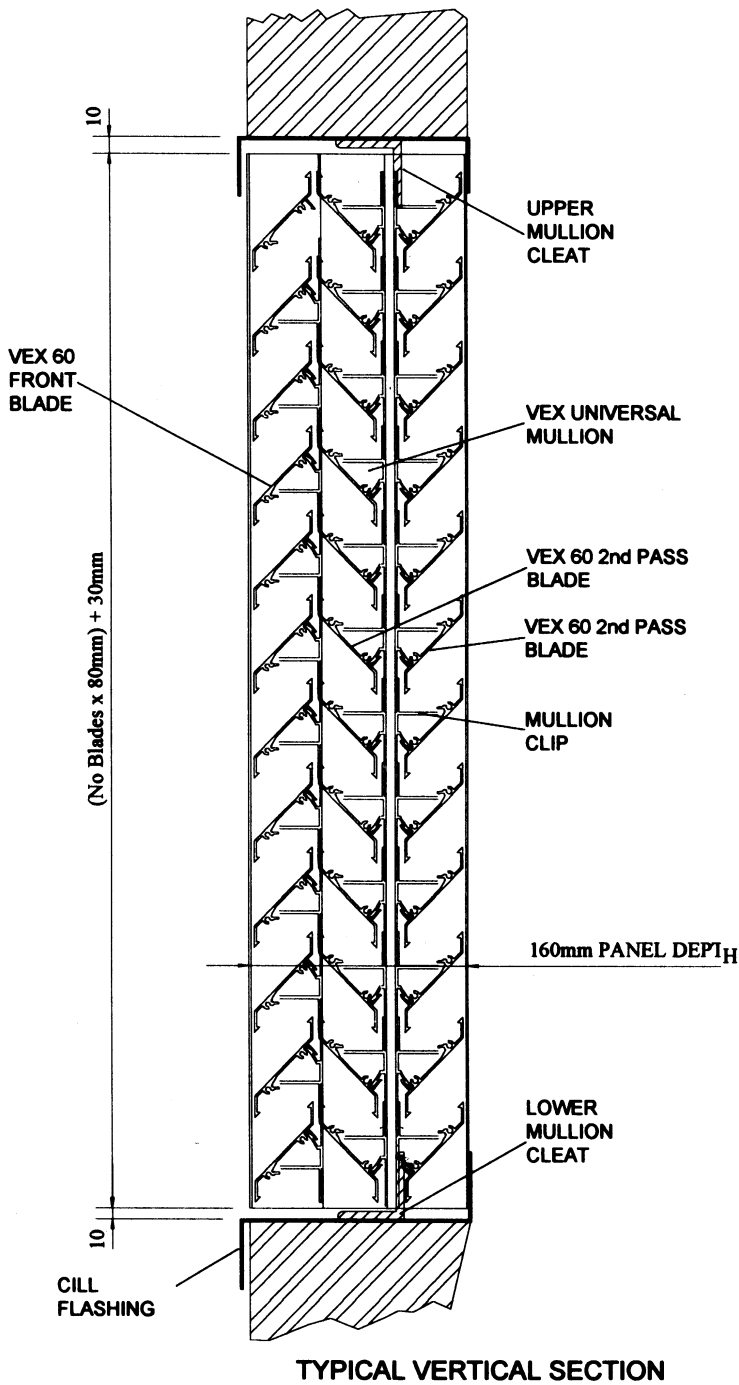

General

High performance fully tested louvre system - Structurally / Weatherability / Aerodynamically

Blades

Extruded aluminium HE9TF, vertical pitch 60mm with integral aluminium clip system. Site assembled triple pass configuration.

Mullions

Mullions can either be constructed from extruded aluminium (HE9TF) or press-formed 2mm thick aluminium sheet metal. Factory fitted with durable aluminium "snap on" clips.

Flashings

Flashings are constructed from aluminium sheet 1.5mm / 2.0mm / 3.0mm thick.

Birdguard

Expanded aluminium mesh (flattened) supplied in sheets with fixings for site installation.

Insect Mesh

Fine woven aluminium mesh supplied in rolls with fixings for site installation.

Blanking Panels

Aluminium sheet 1.0mm / 1.5mm / 2.0mm thick. Composite insulated panels available to suit specific thermal requirements.

Corners

Internal/External corner blades fully welded or cleated to suit corner angle.

Cleats Standard range of fixing cleats supplied to suit individual installations.

Site Fixings

Fixings can be supplied to suit individual installations if required.

Steelwork

Secondary steelwork systems are available if required, designed to suit individual applications.

Finish

Options - Mill finished aluminium - Polyester powder coated to a comprehensive range of colours - Anodised AA5 / AA25 Natural / Coloured.

Free Area

48% geometric free area through the blades.

Performance

Refer to 'Pressure Drop' and 'Weatherability' Performance Data Sheets.

Weight

36.0 Kg/m² (nom) face area when with standard Universal Mullion.

Zefyr Group

Top Barn Business Centre, Holt Heath, Worcestershire, WR6 6NH, UK. Tel +44 (0)870 600 1356 Fax +44 (0)870 600 1357
E-mail mail@zefyrgroup.com website www.zefyrgroup.com

Standard 80 Continuous Louvre

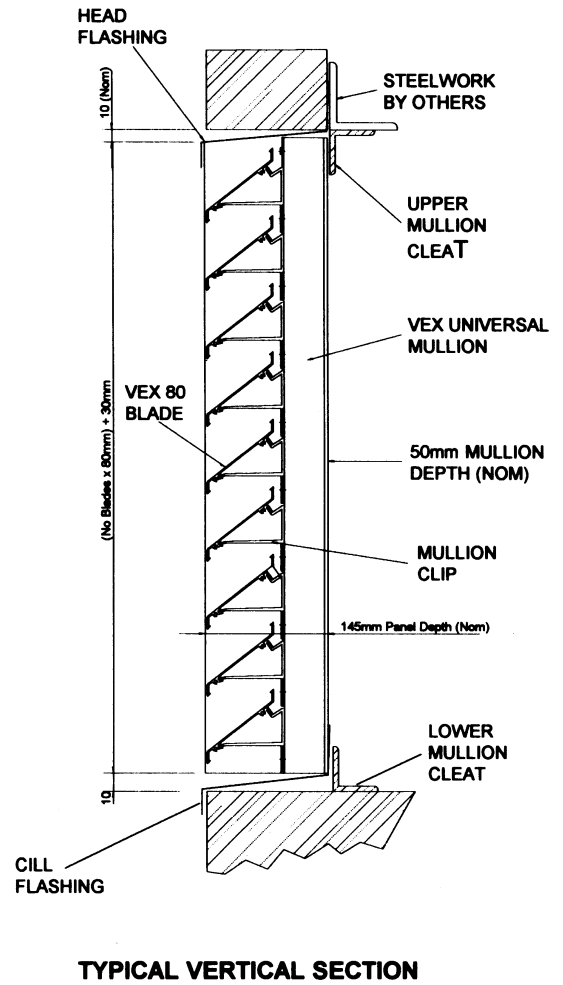
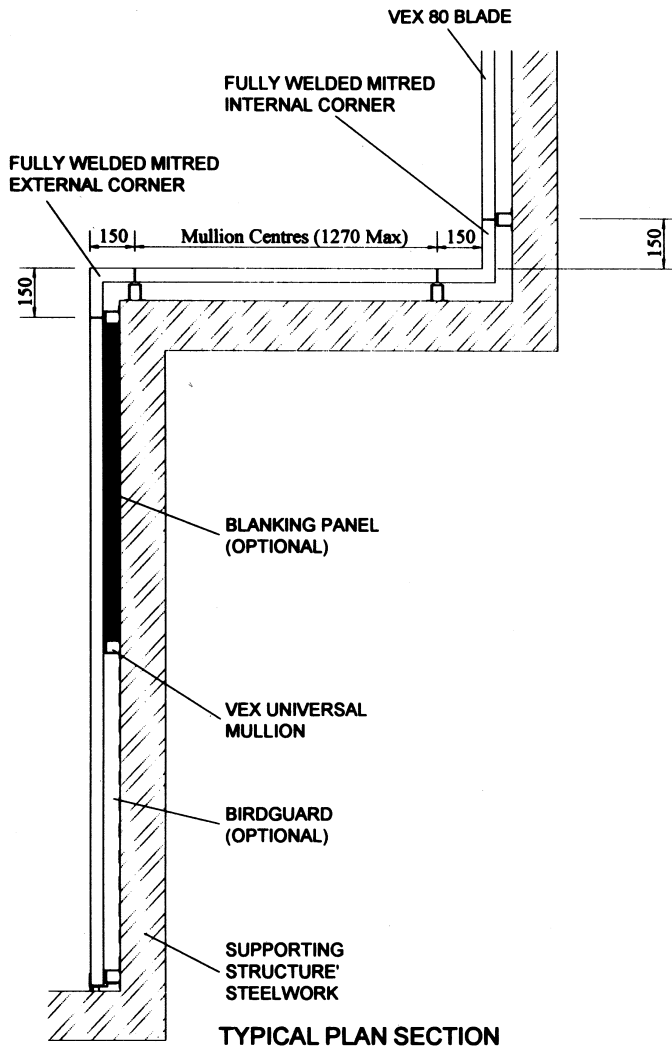

General

Fully tested louvre system - Structurally / Weatherability / Aerodynamically

Blades

Extruded aluminium HE9TF, vertical pitch 80mm with integral aluminium clip system.

Mullions

Mullions can either be constructed from extruded aluminium (HE9TF) or press-formed 2mm thick aluminium sheet metal. Factory fitted with durable aluminium "snap on" clips.

Flashings

Flashings are constructed from aluminium sheet 1.5mm / 2.0mm / 3.0mm thick.

Birdguard

Expanded aluminium mesh (flattened) supplied in sheets with fixings for site installation.

Insect Mesh

Fine woven aluminium mesh supplied in rolls with fixings for site installation.

Blanking Panels

Aluminium sheet 1.0mm / 1.5mm / 2.0mm thick.

Composite insulated panels available to suit specific thermal requirements.

Corners

Internal/External corner blades fully welded or cleated to suit corner angle.

Cleats

Standard range of fixing cleats supplied to suit individual installations.

Site Fixings

Fixings can be supplied to suit individual installations if required.

Steelwork

Secondary steelwork systems are available if required, designed to suit individual applications.

Finish

Options - Mill finished aluminium - Polyester powder coated to a comprehensive range of colours - Anodised AA5 / AA25 Natural / Coloured.

Free Area

48% geometric free area through the blades.

Performance

Refer to 'Pressure Drop' and 'Weatherability' Performance Data Sheets.

Weight

15.10 Kg/m² (nom) face area when with standard Universal Mullion.

Zefyr Group

Top Barn Business Centre, Holt Heath, Worcestershire, WR6 6NH, UK. Tel +44 (0)870 600 1356 Fax +44 (0)870 600 1357

E-mail mail@zefyrgroup.com website www.zefyrgroup.com

Standard 80 Continuous Double Pass Louvre

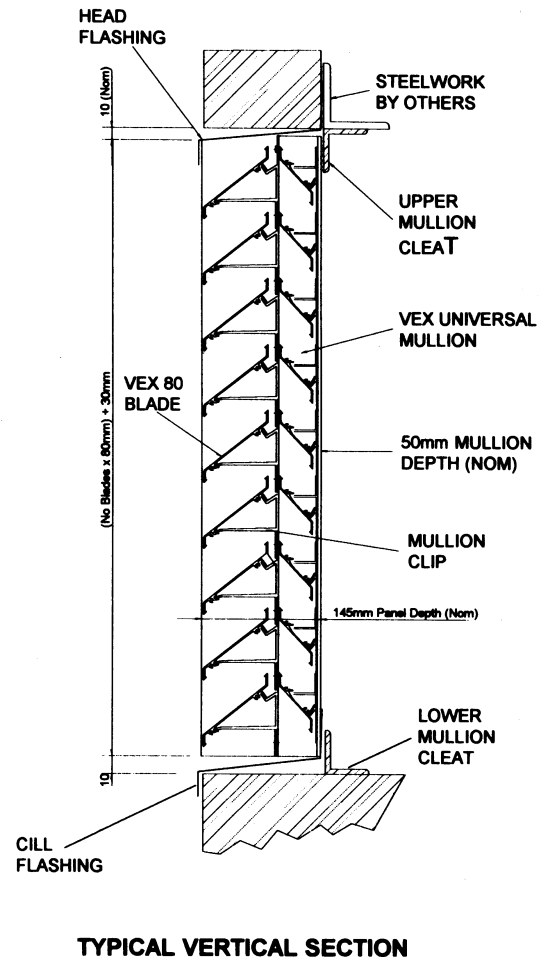
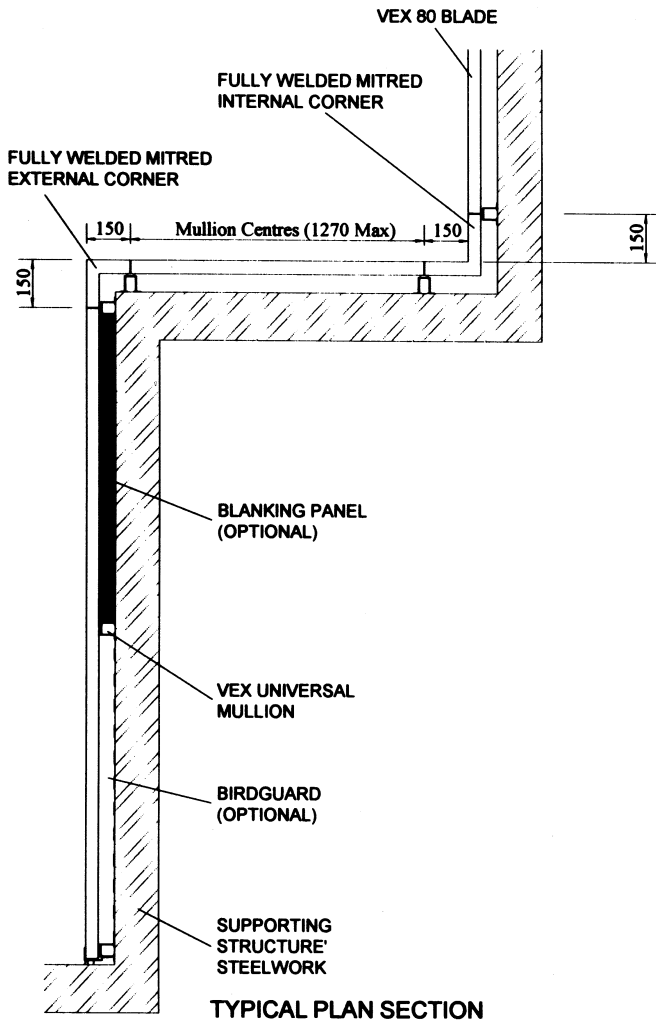

General

Fully tested louvre system - Structurally / Weatherability / Aerodynamically

Blades

Extruded aluminium HE9TF, vertical pitch 80mm with integral aluminium clip system. Site assembled double pass configuration.

Mullions

Mullions can either be constructed from extruded aluminium (HE9TF) or press-formed 2mm thick aluminium sheet metal. Factory fitted with durable aluminium "snap on" clips.

Flashings

Flashings are constructed from aluminium sheet 1.5mm / 2.0mm / 3.0mm thick.

Birdguard

Expanded aluminium mesh (flattened) supplied in sheets with fixings for site installation.

Insect Mesh

Fine woven aluminium mesh supplied in rolls with fixings for site installation.

Blanking Panels

Aluminium sheet 1.0mm / 1.5mm / 2.0mm thick.

Composite insulated panels available to suit specific thermal requirements.

Corners

Internal/External corner blades fully welded or cleated to suit corner angle.

Cleats

Standard range of fixing cleats supplied to suit individual installations.

Site Fixings

Fixings can be supplied to suit individual installations if required.

Steelwork

Secondary steelwork systems are available if required, designed to suit individual applications.

Finish

Options - Mill finished aluminium - Polyester powder coated to a comprehensive range of colours - Anodised AA5 / AA25 Natural / Coloured.

Free Area

48% geometric free area through the blades.

Performance

Refer to 'Pressure Drop' and 'Weatherability' Performance Data Sheets.

Weight

25.41 Kg/m² (nom) face area when with standard Universal Mullion.

Zefyr Group

Top Barn Business Centre, Holt Heath, Worcestershire, WR6 6NH, UK. Tel +44 (0)870 600 1356 Fax +44 (0)870 600 1357

E-mail mail@zefyrgroup.com website www.zefyrgroup.com

Standard 100 Continuous Louvre

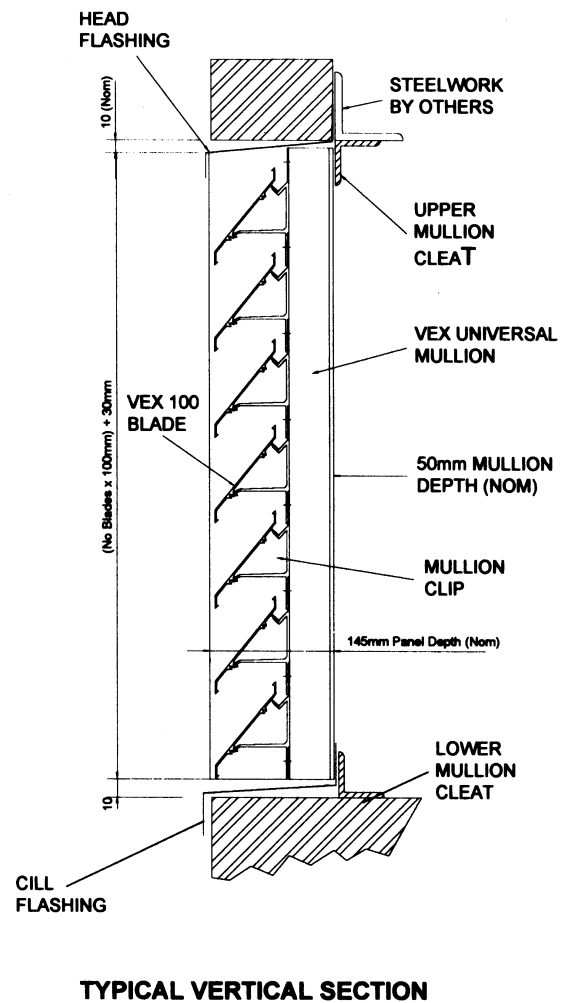
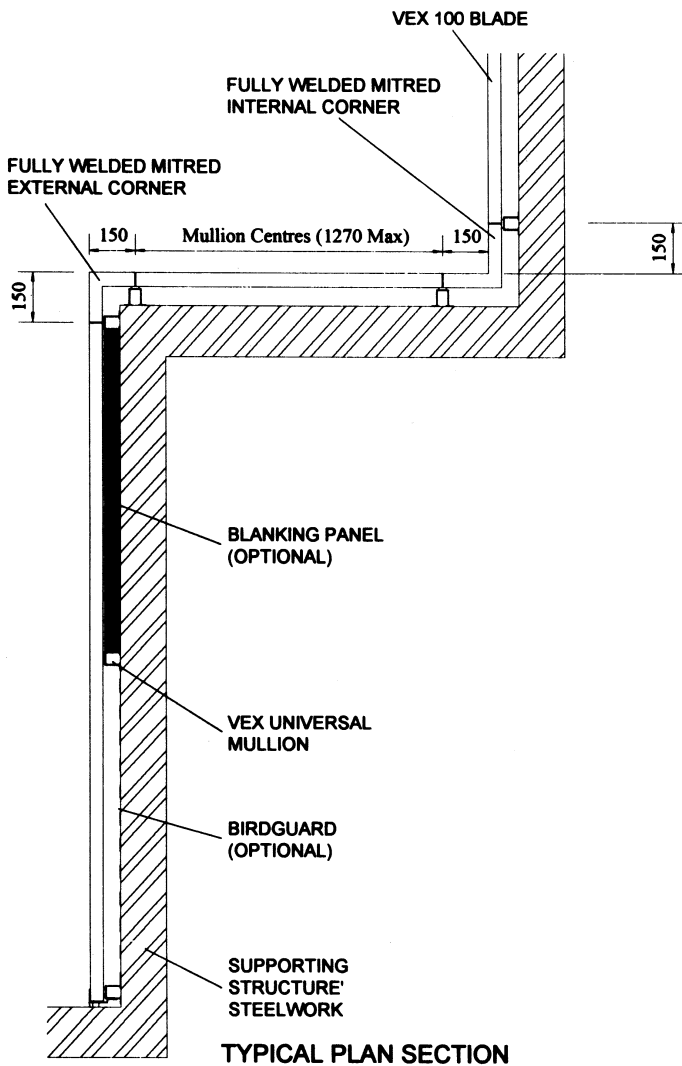

General

Fully tested louvre system - Structurally / Weatherability / Aerodynamically

Blades

Extruded aluminium HE9TF vertical pitch - 100mm with integral aluminium clip system.

Mullions

Mullions can either be constructed from extruded aluminium (HE9TF) or press-formed 2mm thick aluminium sheet metal. Factory fitted with durable aluminium "snap on" clips.

Flashings

Flashings are constructed from aluminium sheet 1.5mm / 2.0mm / 3.0mm thick.

Birdguard

Expanded aluminium mesh (flattened) supplied in sheets with fixings for site installation.

Insect Mesh

Fine woven aluminium mesh supplied in rolls with fixings for site installation.

Blanking Panels

Aluminium sheet 1.0mm / 1.5mm / 2.0mm thick. Composite insulated panels available to suit specific thermal requirements.

Corners

Internal/External corner blades fully welded or cleated to suit corner angle.

Cleats

Standard range of fixing cleats supplied to suit individual installations.

Site Fixings

Fixings can be supplied to suit individual installations if required.

Steelwork

Secondary steelwork systems are available if required, designed to suit individual applications.

Finish

Options - Mill finished aluminium - Polyester powder coated to a comprehensive range of colours - Anodised AA5 / AA25 Natural / Coloured.

Free Area

48% geometric free area through the blades.

Performance

Refer to 'Pressure Drop' and 'Weatherability' Performance Data Sheets.

Weight

12.00 Kg/m² (nom) face area when with standard Universal Mullion.

Zefyr Group

Top Barn Business Centre, Holt Heath, Worcestershire, WR6 6NH, UK. Tel +44 (0)870 600 1356 Fax +44 (0)870 600 1357

E-mail mail@zefyrgroup.com website www.zefyrgroup.com

Standard 100 Continuous Double Pass Louvre

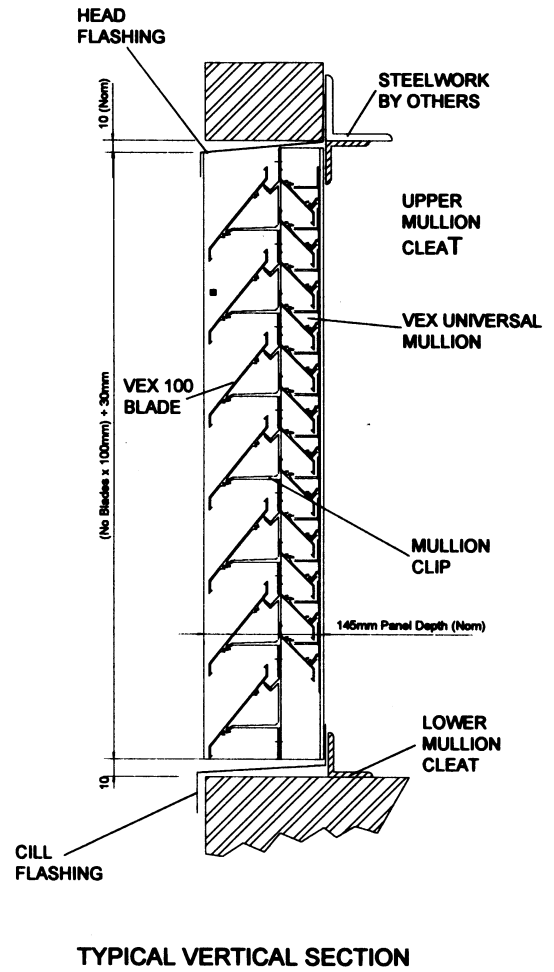
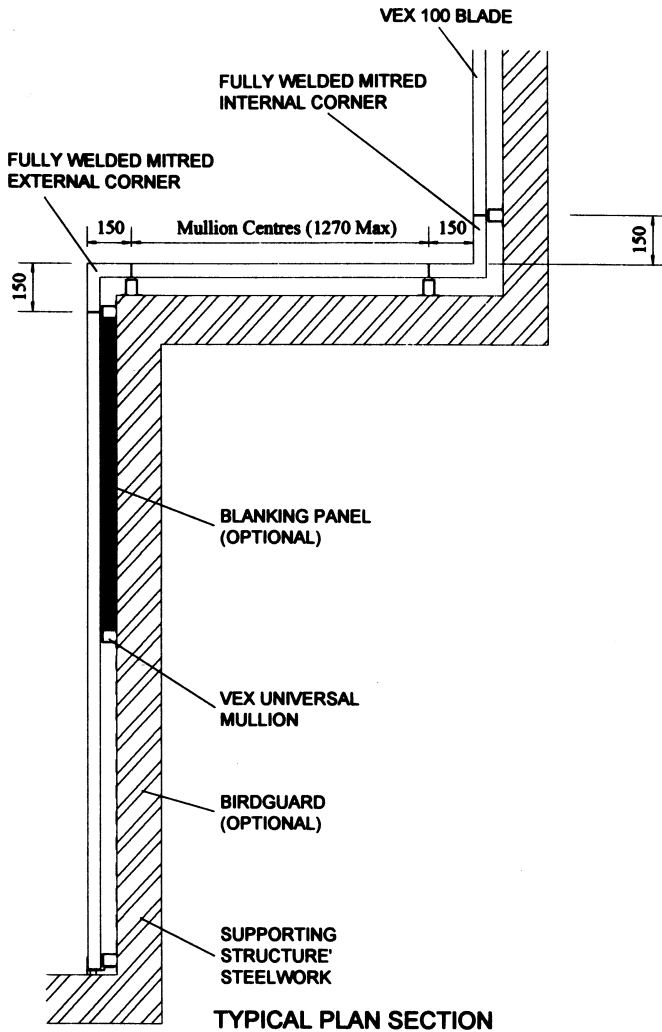

General

Fully tested louvre system - Structurally / Weatherability / Aerodynamically

Blades

Extruded aluminium HE9TF vertical pitch - 100mm with integral aluminium clip system. Site assembled double pass configuration.

Mullions

Mullions can either be constructed from extruded aluminium (HE9TF) or press-formed 2mm thick aluminium sheet metal. Factory fitted with durable aluminium "snap on" clips.

Flashings

Flashings are constructed from aluminium sheet 1.5mm / 2.0mm / 3.0mm thick.

Birdguard

Expanded aluminium mesh (flattened) supplied in sheets with fixings for site installation.

Insect Mesh

Fine woven aluminium mesh supplied in rolls with fixings for site installation.

Blanking Panels

Aluminium sheet 1.0mm / 1.5mm / 2.0mm thick.

Composite insulated panels available to suit specific thermal requirements.

Corners

Internal/External corner blades fully welded or cleated to suit corner angle.

Cleats

Standard range of fixing cleats supplied to suit individual installations.

Site Fixings

Fixings can be supplied to suit individual installations if required.

Steelwork

Secondary steelwork systems are available if required, designed to suit individual applications.

Finish

Options - Mill finished aluminium - Polyester powder coated to a comprehensive range of colours - Anodised AA5 / AA25 Natural / Coloured.

Free Area

48% geometric free area through the blades.

Performance

Refer to 'Pressure Drop' and 'Weatherability' Performance Data Sheets.

Weight

23.50 Kg/m² (nom) face area when with standard Universal Mullion.

Zefyr Group

Top Barn Business Centre, Holt Heath, Worcestershire, WR6 6NH, UK. Tel +44 (0)870 600 1356 Fax +44 (0)870 600 1357

E-mail mail@zefyrgroup.com website www.zefyrgroup.com

Standard 60 Modular Louvre

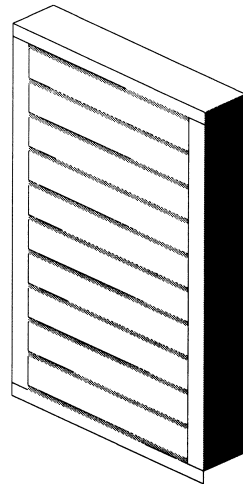

ISOMETRIC VIEW

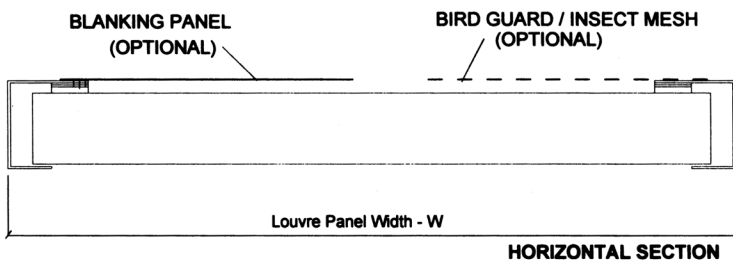

HORIZONTAL SECTION

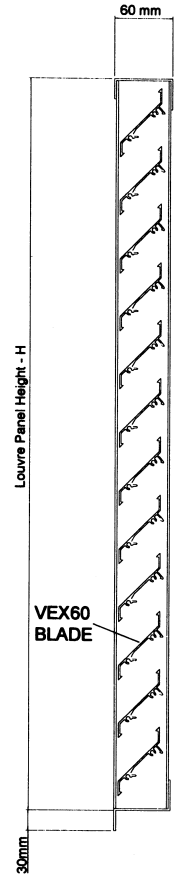

VERTICAL SECTION

General

Fully tested louvre system - Structurally / Weatherability / Aerodynamically

Blades

Extruded aluminium HE9TF vertical pitch - 60mm with integral aluminium clip / concealed fixing system.

Dimensional Data		
No of Blades	Module Height (mm)	Module Max Width (mm)
6	395	3000
7	455	3000
8	515	3000
9	575	3000
10	635	3000
11	695	3000
12	755	3000
13	815	3000
14	875	3000
15	935	3000
16	995	3000
17	1055	3000
18	1115	3000
19	1175	2500
20	1235	2500
21	1295	2500
22	1355	2500
23	1415	2500
24	1475	2500
25	1535	2500
26	1595	2500
27	1655	2500
28	1715	2500
29-	1775-	1250
49 max	2975	1250

Frames

Constructed from extruded aluminium (HE9TF) or press-formed 1.5mm / 2.0mm / 3.0mm thick aluminium sheet metal.

Flashings

Vex Modular Louvres are designed to fit into fully prepared openings. If required, flashings are constructed from aluminium sheet 1.5mm / 2.0mm / 3.0mm thick.

Birdguard

Expanded aluminium mesh (flattened) factory fitted to louvre panels (optional).

Insect Mesh

Fine woven aluminium mesh factory fitted to louvre panels (optional).

Blanking Panels

Aluminium sheet 1.0mm / 1.5mm / 2.0mm thick (optional).

Composite insulated panels available to suit specific thermal requirements (optional).

Cleats

Standard range of fixing cleats supplied to suit individual installations (optional).

Site Fixings

Fixings can be supplied to suit individual installations if required.

Steelwork

Secondary steelwork systems are available if required, designed to suit individual applications.

Finish

Options - Mill finished aluminium - Polyester powder coated to a comprehensive range of colours Anodised AA5 / AA25 Natural / Coloured.

Free Area

48% geometric free area through the blades.

Performance

Refer to 'Pressure Drop' and 'Weatherability' Performance Data Sheets

Weight

11.62 Kg/m² (nom) face area.

Zefyr Group

Top Barn Business Centre, Holt Heath, Worcestershire, WR6 6NH, UK. Tel +44 (0)870 600 1356 Fax +44 (0)870 600 1357

E-mail mail@zefyrgroup.com website www.zefyrgroup.com

Standard 80 Modular Louvre

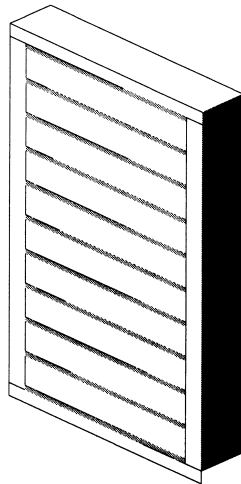

ISOMETRIC VIEW

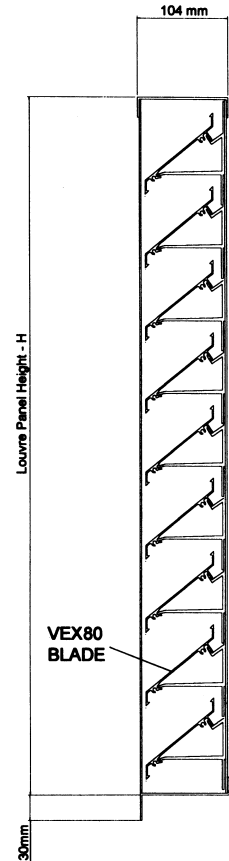
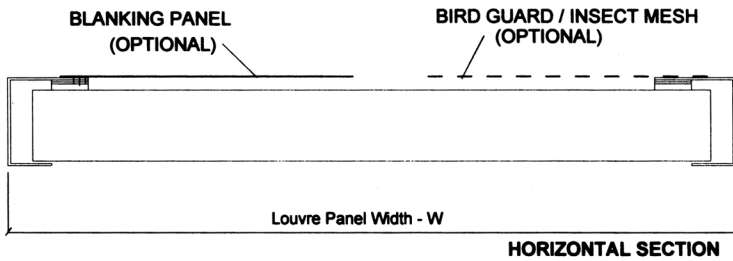

General

Fully tested louvre system - Structurally / Weatherability / Aerodynamically

Blades

Extruded aluminium HE9TF vertical pitch - 80mm with integral aluminium clip / concealed fixing system.

Dimensional Data		
No of Blades	Module Height (mm)	Module Max Width (mm)
6	520	3000
7	600	3000
8	680	3000
9	760	3000
10	840	3000
11	920	3000
12	1000	3000
13	1080	3000
14	1160	3000
15	1240	2500
16	1320	2500
17	1400	2500
18	1480	2500
19	1560	2500
20	1640	2500
21	1720	2500
22	1800	2500
23	1880	2500
24	1960	1250
25	2040	1250
26	2120	1250
27	2200	1250
28	2280	1250
29+	2360	1250
36 max	2920	1250

Frames

Constructed from extruded aluminium (HE9TF) or press-formed 1.5mm / 2.0mm / 3.0mm thick aluminium sheet metal.

Flashings

Vex Modular Louvres are designed to fit into fully prepared openings. If required, flashings are constructed from aluminium sheet 1.5mm / 2.0mm / 3.0mm thick.

Birdguard

Expanded aluminium mesh (flattened) factory fitted to louvre panels (optional).

Insect Mesh

Fine woven aluminium mesh factory fitted to louvre panels (optional).

Blanking Panels

Aluminium sheet 1.0mm / 1.5mm / 2.0mm thick (optional). Composite insulated panels available to suit specific thermal requirements (optional).

Cleats

Standard range of fixing cleats supplied to suit individual installations (optional).

Site Fixings

Fixings can be supplied to suit individual installations if required.

Steelwork

Secondary steelwork systems are available if required, designed to suit individual applications.

Finish

Options - Mill finished aluminium - Polyester powder coated to a comprehensive range of colours - Anodised AA5 / AA25 Natural / Coloured.

Free Area

48% geometric free area through the blades.

Performance

Refer to 'Pressure Drop' and 'Weatherability' Performance Data Sheets

Weight

11.62 Kg/m² (nom) face area.

VERTICAL SECTION

Zefyr Group

Top Barn Business Centre, Holt Heath, Worcestershire, WR6 6NH, UK. Tel +44 (0)870 600 1356 Fax +44 (0)870 600 1357

E-mail mail@zefyrgroup.com website www.zefyrgroup.com

Standard 100 Modular Louvre

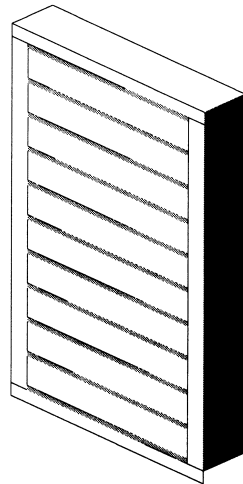

ISOMETRIC VIEW

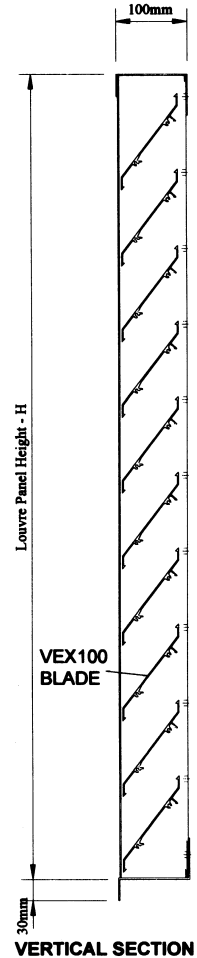
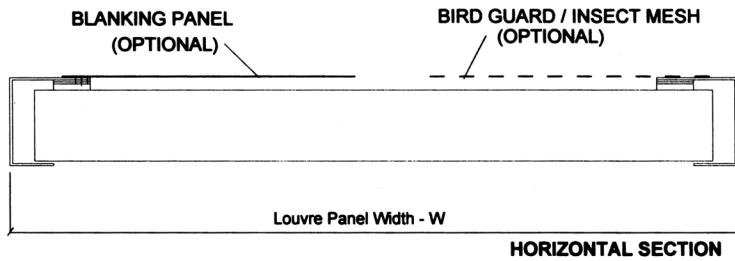

General

Fully tested louvre system - Structurally / Weatherability / Aerodynamically

Blades

Extruded aluminium HE9TF vertical pitch - 100mm with integral aluminium clip / concealed fixing system.

Dimensional Data		
No of Blades	Module Height (mm)	Module Max Width (mm)
5	550	3000
6	650	3000
7	750	3000
8	850	3000
9	950	3000
10	1050	3000
11	1150	3000
12	1250	2500
13	1350	2500
14	1450	2500
15	1550	2500
16	1650	2500
17	1750	2500
18	1850	2500
19	1950	1250
20	2050	1250
21	2150	1250
22	2250	1250
23	2350	1250
24	2450	1250
25	2550	1250
26	2650	1250
27	2750	1250
28	2850	1250
29	2950	1250

Frames

Constructed from extruded aluminium (HE9TF) or press-formed 1.5mm / 2.0mm / 3.0mm thick aluminium sheet metal.

Flashings

Vex Modular Louvres are designed to fit into fully prepared openings. If required, flashings are constructed from aluminium sheet 1.5mm / 2.0mm / 3.0mm thick.

Birdguard

Expanded aluminium mesh (flattened) factory fitted to louvre panels (optional).

Insect Mesh

Fine woven aluminium mesh factory fitted to louvre panels (optional).

Blanking Panels

Aluminium sheet 1.0mm / 1.5mm / 2.0mm thick (optional). Composite insulated panels available to suit specific thermal requirements (optional).

Cleats

Standard range of fixing cleats supplied to suit individual installations (optional).

Site Fixings

Fixings can be supplied to suit individual installations if required.

Steelwork

Secondary steelwork systems are available if required, designed to suit individual applications.

Finish

Options - Mill finished aluminium - Polyester powder coated to a comprehensive range of colours - Anodised AA5 / AA25 Natural / Coloured.

Free Area

48% geometric free area through the blades.

Performance

Refer to 'Pressure Drop' and 'Weatherability' Performance Data Sheets

Weight

13.25 Kg/m² (nom).

Zefyr Group

Top Barn Business Centre, Holt Heath, Worcestershire, WR6 6NH, UK. Tel +44 (0)870 600 1356 Fax +44 (0)870 600 1357

E-mail mail@zefyrgroup.com website www.zefyrgroup.com

Standard 80 Modular Operable Louvre



General

Fully tested louvre system - Structurally / Weatherability / Aerodynamically

Blades

Extruded aluminium HE9TF vertical pitch - 80mm with integral aluminium clip / concealed fixing system.

Frames

Constructed from extruded aluminium (HE9TF) or press-formed 1.5mm / 2.0mm / 3.0mm thick aluminium sheet metal.

Flashings

Std Modular Louvres are designed to fit into fully prepared openings. If required, flashings are constructed from aluminium sheet 1.5mm / 2.0mm / 3.0mm thick.

Birdguard

Expanded aluminium mesh (flattened) factory fitted to louvre panels (optional).

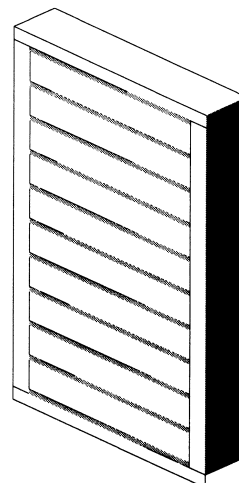

ISOMETRIC VIEW

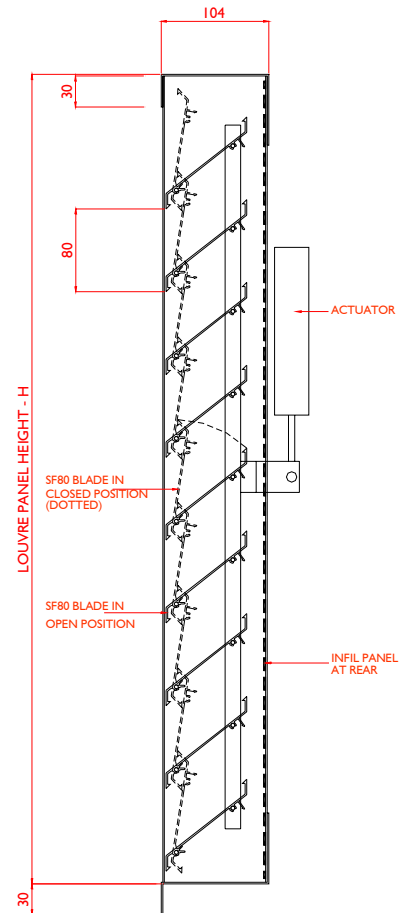
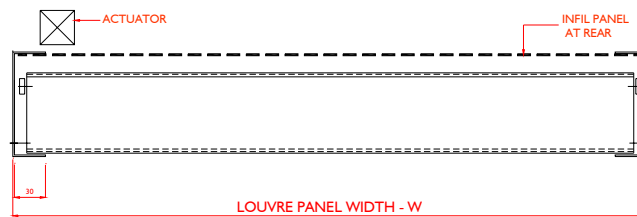

Dimensional Data		
No of Blades	Module Height (mm)	Module Max Width (mm)
6	520	3000
7	600	3000
8	680	3000
9	760	3000
10	840	3000
11	920	3000
12	1000	3000
13	1080	3000
14	1160	3000
15	1240	2500
16	1320	2500
17	1400	2500
18	1480	2500
19	1560	2500
20	1640	2500
21	1720	2500
22	1800	2500
23	1880	2500
24	1960	1250
25	2040	1250
26	2120	1250
27	2200	1250
28	2280	1250
29+	2360	1250
36 max	2920	1250

Insect Mesh

Fine woven aluminium mesh factory fitted to louvre panels (optional).

Blanking Panels

Aluminium sheet 1.0mm / 1.5mm / 2.0mm thick (optional). Composite insulated panels available to suit specific thermal requirements (optional).

Cleats

Standard range of fixing cleats supplied to suit individual installations (optional).

Site Fixings

Fixings can be supplied to suit individual installations if required.

Steelwork

Secondary steelwork systems are available if required, designed to suit individual applications.

Finish

Options - Mill finished aluminium - Polyester powder coated to a comprehensive range of colours - Anodised AA5 / AA25 Natural / Coloured.

Free Area

54% geometric free area through the blades.

Performance

Refer to 'Pressure Drop' and 'Weatherability' Performance Data Sheets

Operation Options

- Manual
- Winder
- Pneumatic
- Electric (240vac / 24vdc)

Weight

12.5 Kg/m² (nom) face area.

Zefyr Group

Top Barn Business Centre, Holt Heath, Worcestershire, WR6 6NH, UK. Tel +44 (0)870 600 1356 Fax +44 (0)870 600 1357

E-mail mail@zefyrgroup.com website www.zefyrgroup.com

Aerodynamic Performance

The 'STANDARD' Louvre system has been comprehensively tested. The testing data has been presented in System format. Other suppliers of louvres sometimes use performance data for the louvre blades only. This is misleading and can result in the incorrect selection if not used correctly. The development of these louvres systems was part of a major programme spanning over 30 years independently controlled in the USA and the UK by Loughborough Consultants, a specialist division of the University of Technology at Loughborough.

Test Procedure

Louvre modules were fitted into the EPTC wind tunnel calibrated wall. The airflow was increased and the pressure drop across the louvre was recorded using calibrated measuring equipment.

TEST RESULTS – GRAPHS

Standard 60 PRESSURE DROP CURVES

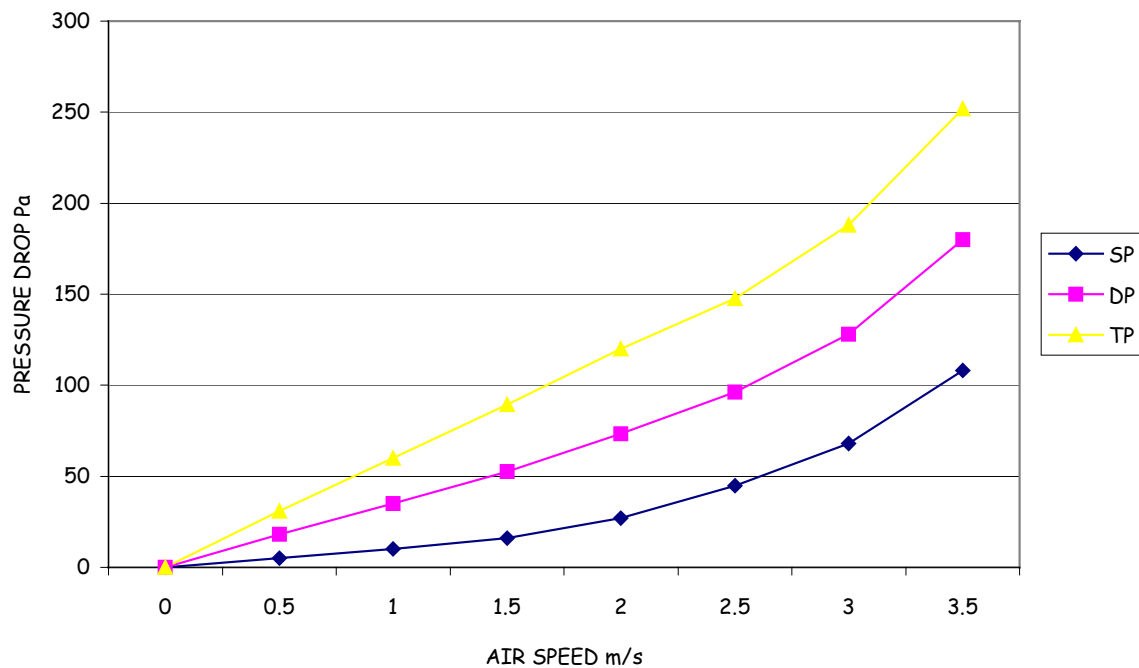

VEX80 PRESSURE DROP CURVES

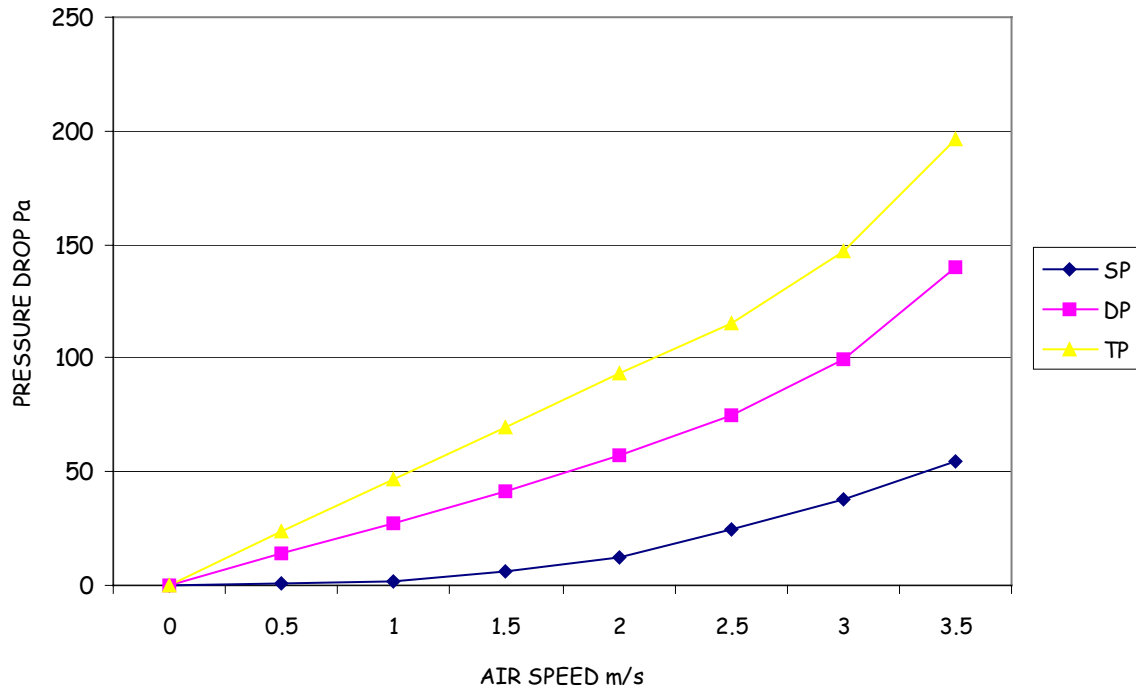

VEX100 PRESSURE DROP CURVES

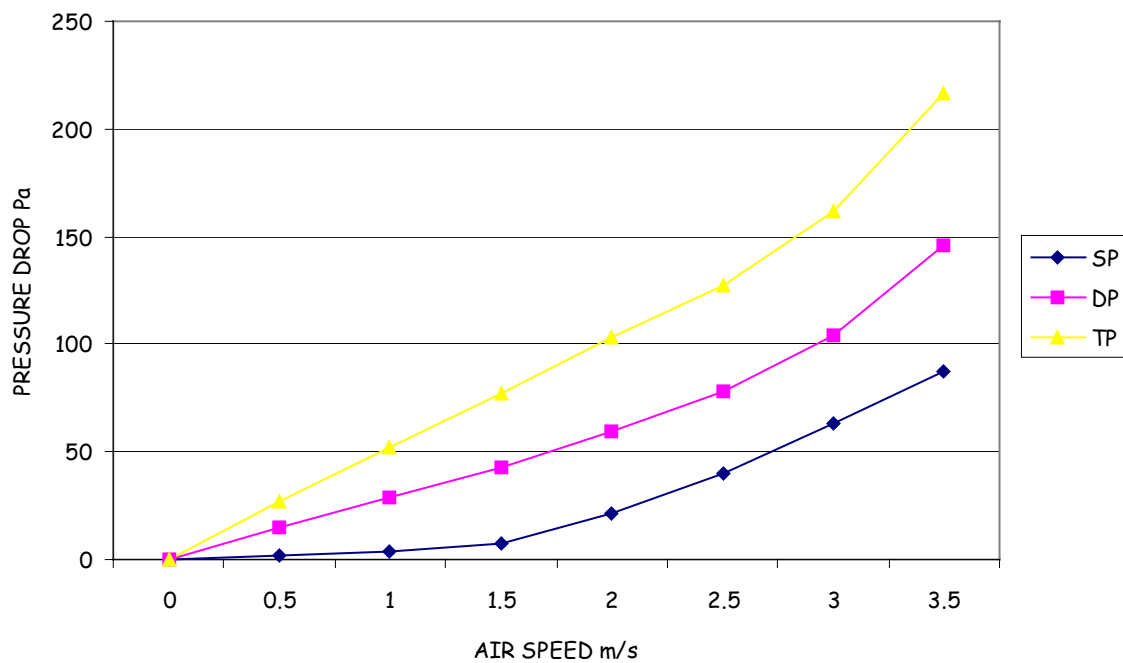



Weatherability

Weather Test Procedure

Test Procedure – EPTC / HEVAC

Zefyr Standard Test Criteria:

Method of test for water rejection and louvres subject to simulated rainfall – DT208/93

Test to extreme conditions

No wind	No ventilation
No wind	Ventilation 5 m/s

Wind speed and ventilation combined - 8 m/s

Wind speed - 13m/s

Constant rainfall at 75 mm/hr

Note – the test incorporates the performance requirements required by the HEVAC standard. Note the HEVAC standard only requires a through ventilation rate of 3.5m/s, compared to the RV standard of 5.0m/s.

The attached graph summarises the results under the extreme weather conditions for each of the louvre options.

Weather Test Results - Graphs

Weather Effectiveness VEX 100

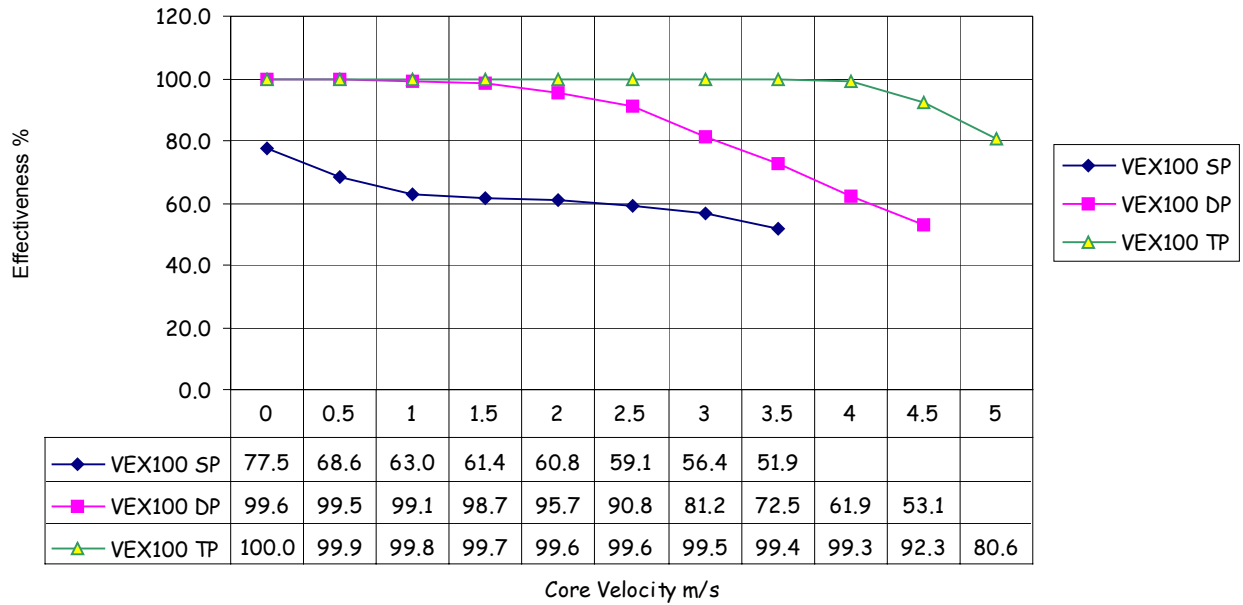

Weather Effectiveness VEX 80

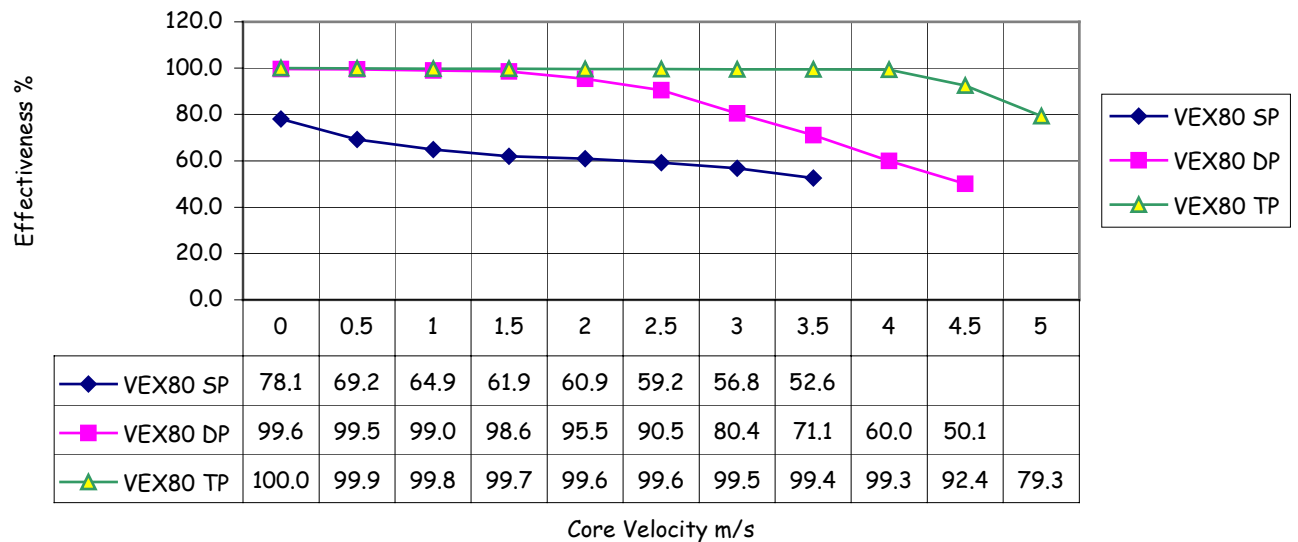

Weather Effectiveness VEX60

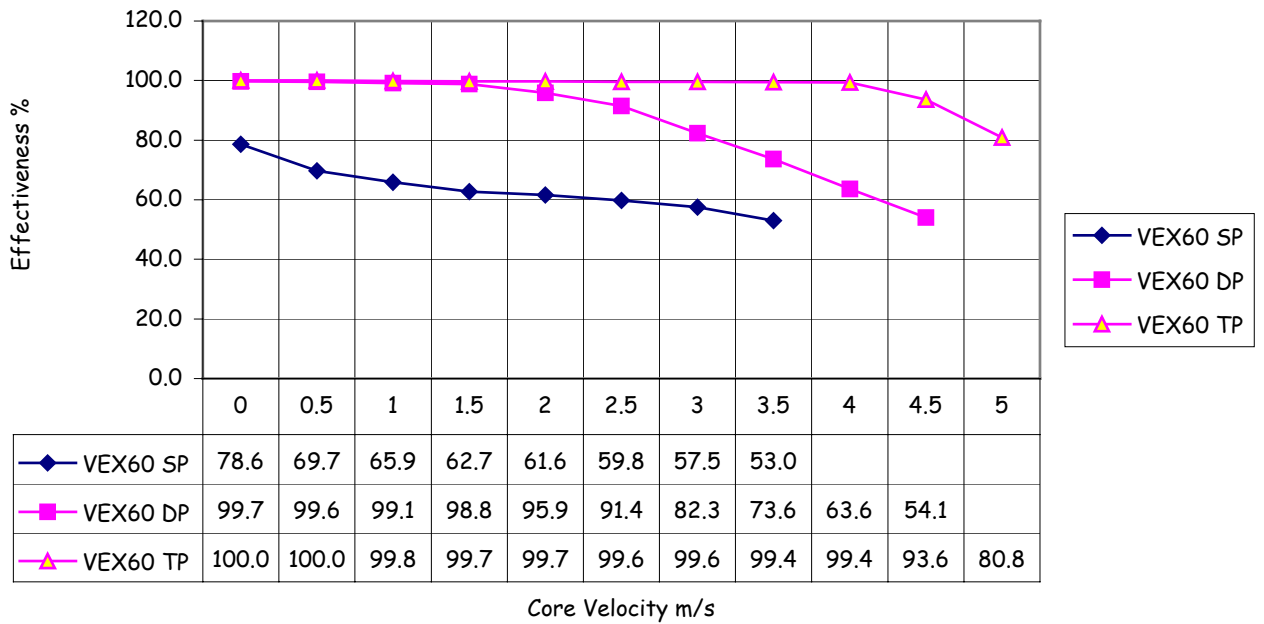



Structural Data – Load / Span

The following tables detail the maximum structural loading characteristics for the 'Standard' louvre systems. The method of calculation is based on the following principles and the criteria detailed within each table.

The analyses splits the systems down into –

Blade Analysis

Modular Louvre Analysis / Tables

Continuous Louvre Analysis / Tables

Fixings Analysis

The principles are detailed by examples as follows –

Note - the following calculations are based on specific criteria. For particular requirements please contact your nearest technical office or e-mail mail@zefyrgroup.com.

Zefyr Group

Top Barn Business Centre, Holt Heath, Worcestershire, WR6 6NH, UK. Tel +44 (0)870 600 1356 Fax +44 (0)870 600 1357
E-mail mail@zefyrgroup.com website www.zefyrgroup.com

Blade Analysis

Assuming simply support conditions for a uniformly distributed load –

BLADE IN SIMPLY SUPPORTED CONDITION

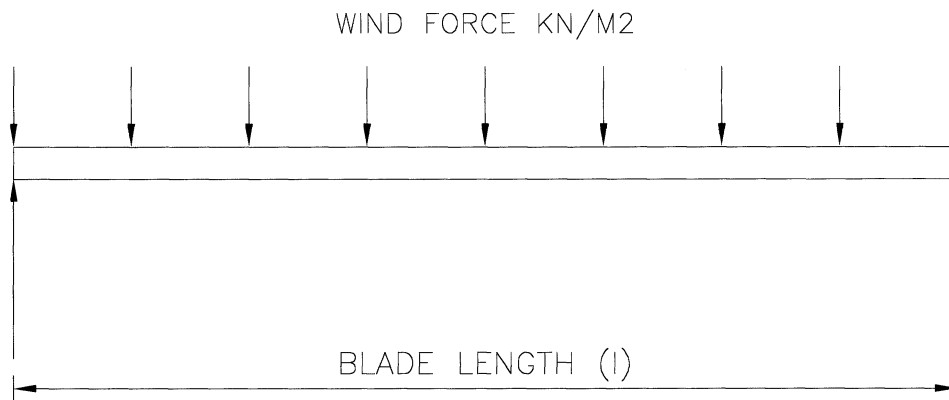

Figure 1.

Assumption – Maximum allowable blade deflection = 5mm

Factor of safety = 1.4

Maximum Blade Length (l) = $(384 \times E \times I / \text{wind} / p)^{1/4}$

Where,

E = 65500 N/mm² (for aluminium)

P = Vertical blade pitch

Wind = Wind load KN/m²

I = I value of blade about its bending axis

Refer to Table 1, overleaf for blade section properties.

Refer to Table 2 for blade span results.

Table I - I Values for standard louvres

STANDARD 60			
	INST ANGLE 45 deg	Major Axis	Bending Axis
Ixx	55680mm ⁴	90820mm ⁴	
Iyy	38970mm ⁴	3430mm ⁴	7923mm ⁴

STANDARD 80			
	INST ANGLE 36 deg	Major Axis	Bending Axis
Ixx	135000mm ⁴	312178mm ⁴	
Iyy	315000mm ⁴	3170mm ⁴	11621mm ⁴

STANDARD 100			
	INST ANGLE 51 deg	Major Axis	Bending Axis
Ixx	267270mm ⁴	422000mm ⁴	
Iyy	158000mm ⁴	2952mm ⁴	15406mm ⁴

Maximum Blade span for STD60, STD80, STD100 Louvres = 1250mm

Modular Louvre Analysis

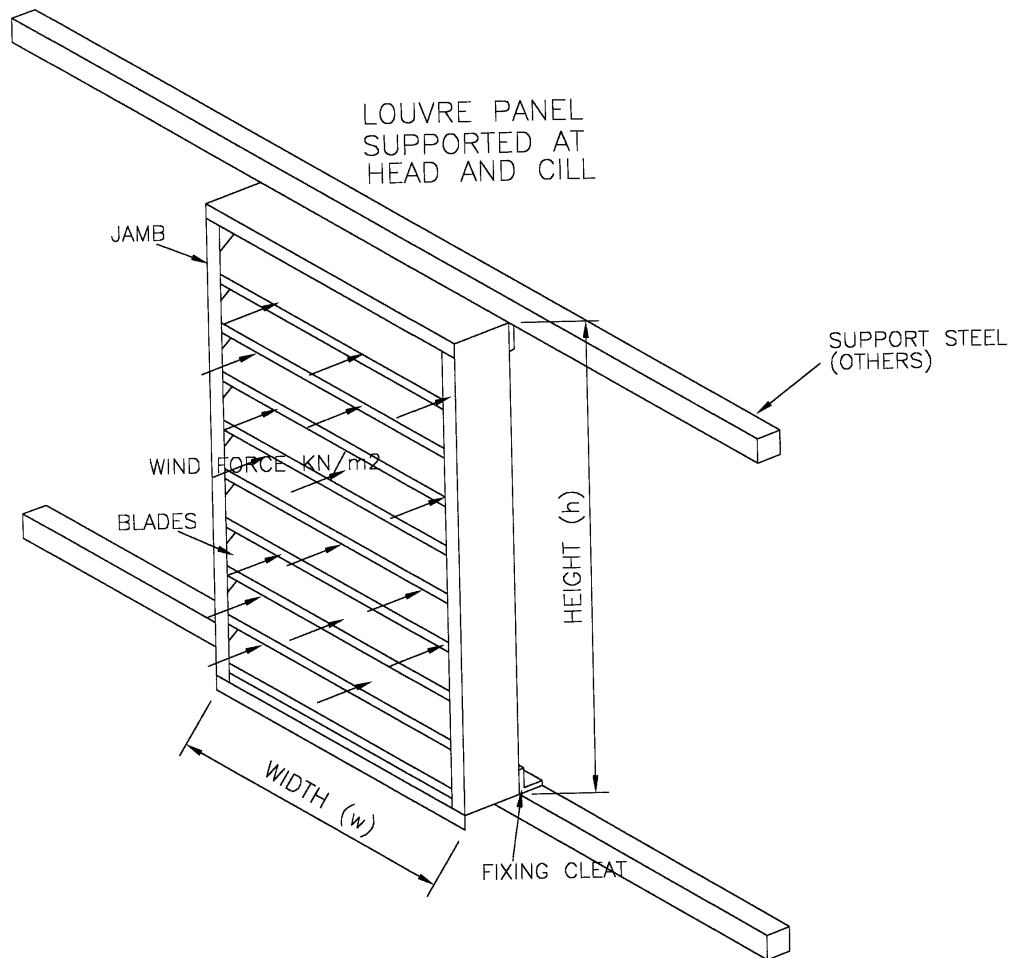

Figure 2

Maximum louvre sizes have been determined with the following considerations –

- Maximum allowable deflection is $h/180$
- Blade span capabilities
- Manufacturing capabilities
- Jamb / mullion structural characteristics
- Site handling practicalities
- Proportion of louvre area subjected to load = 0.8
- Spacing of vertical supports = 1250mm

To determine louvre dimensions use the tables attached with appropriate wind load. If louvre is blanked multiply the wind load by 1.4.



List of Tables for selection of maximum Modular Louvre dimensions.

Table I.1. STD60 Modular Single Pass Single Span

Table I.2. STD80 Single Pass Modular Single Span

Table I.3. STD100 Single Pass Modular Single Span

Table I.4. STD60 Double Pass Modular Single Span

Table I.5. STD80 Double Pass Modular Single Span

Table I.6. STD100 Double Pass Modular Single Span

Table I.7. STD60 Triple Pass Modular Single Span

Table I.8. STD80 Triple Pass Modular Single Span

Table I.9. STD100 Triple Pass Modular Single Span

Table I.1. STD60 Modular Single Pass Single Span

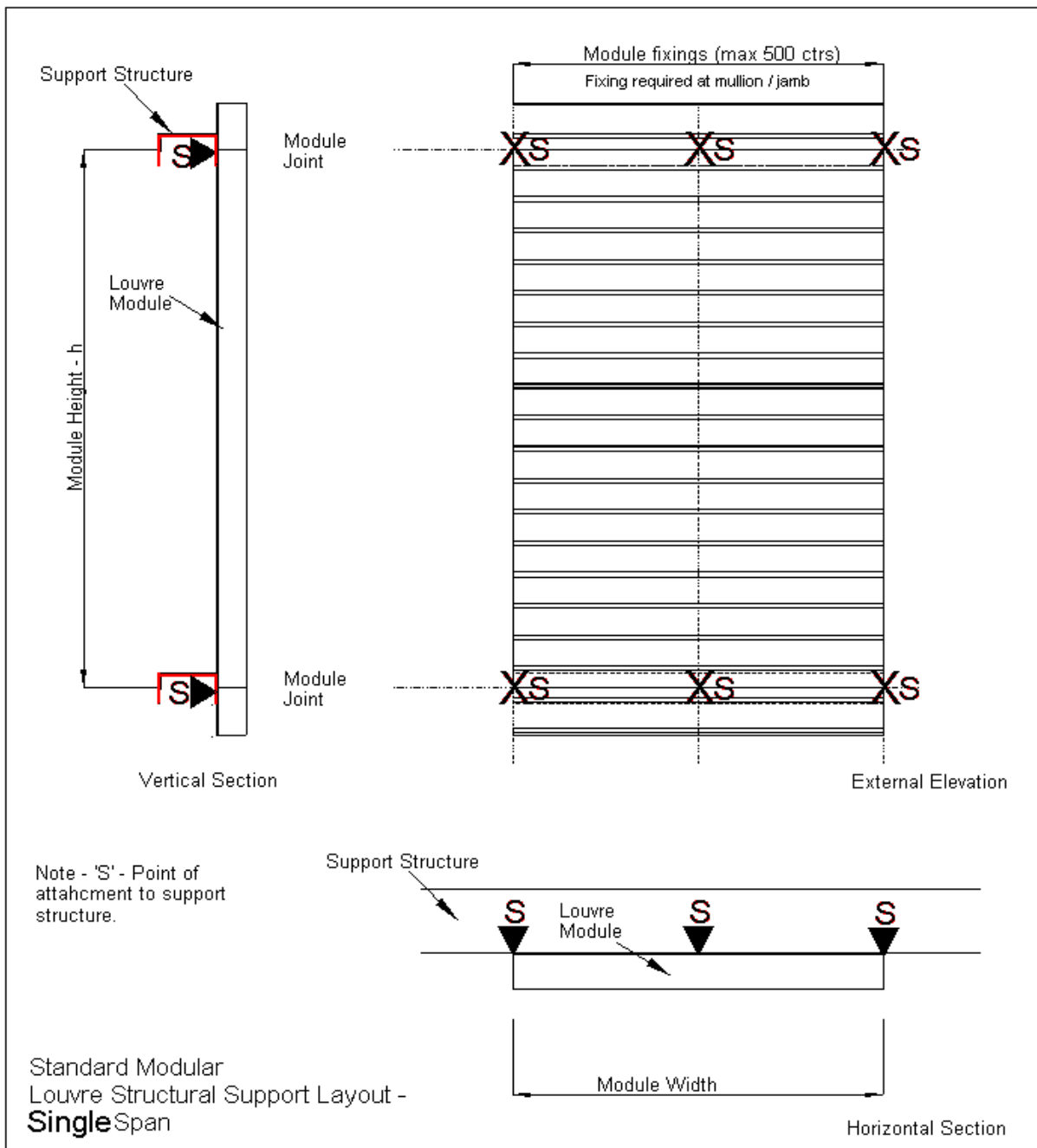

SINGLE PASS STD 60						
Wind Load	0.5 KN/m ²	1 KN/m ²	1.5 KN/m ²	2 KN/m ²	2.5 KN/m ²	3 KN/m ²
Max Unsupported Ht	2100 m	1700 m	1480 m	1350 m	1250 m	1180 m

Table 1.2. STD80 Single Pass Modular Single Span

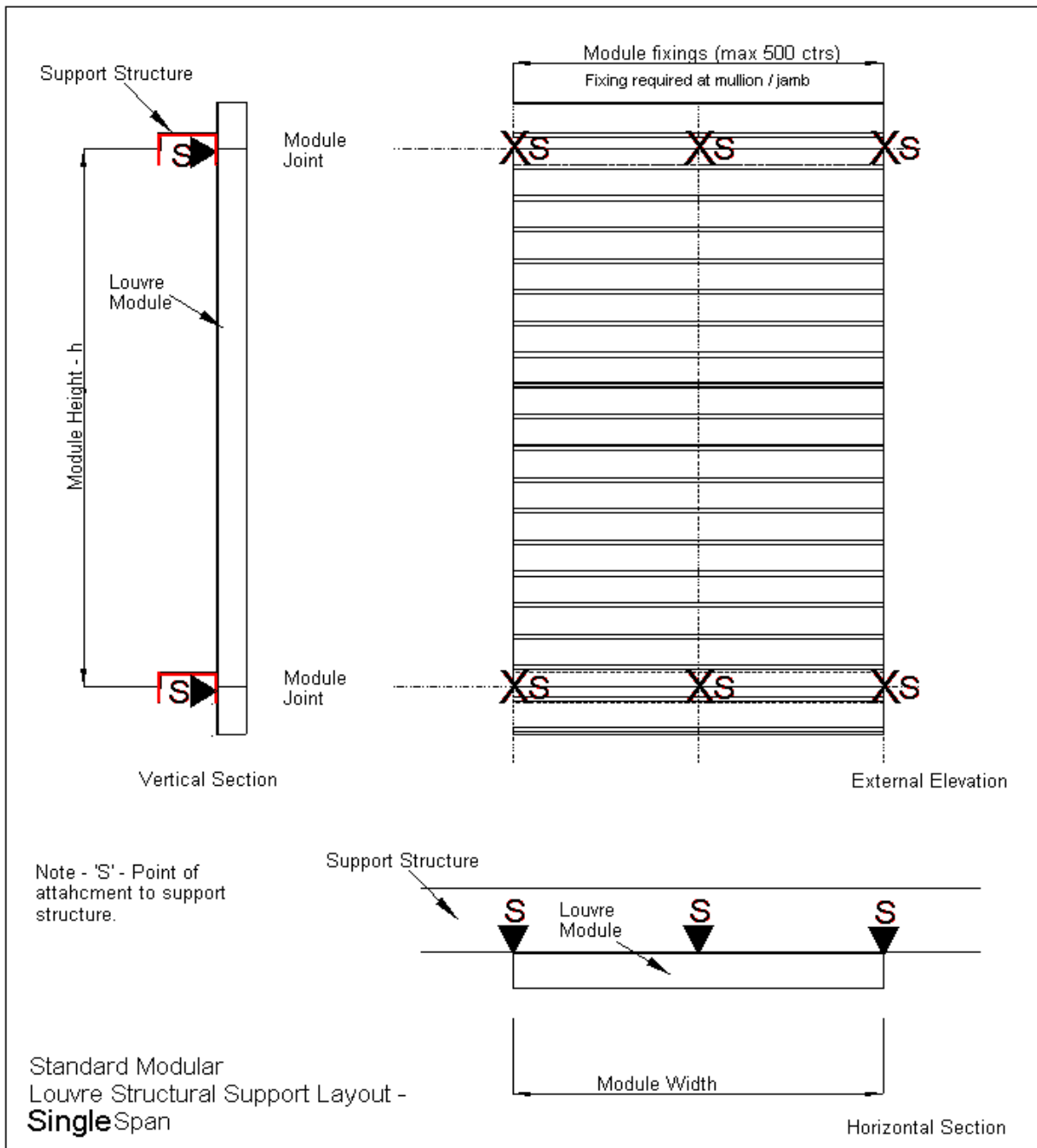

I value of jambs = 320000mm⁴

SINGLE PASS STD80						
Wind Load	0.5 KN/m ²	1 KN/m ²	1.5 KN/m ²	2 KN/m ²	2.5 KN/m ²	3 KN/m ²
Max Unsupported Ht	3000 m	2620 mm	2300 mm	2100 mm	1950 mm	1820 mm

Table 1.3. STD100 Single Pass Modular Single Span

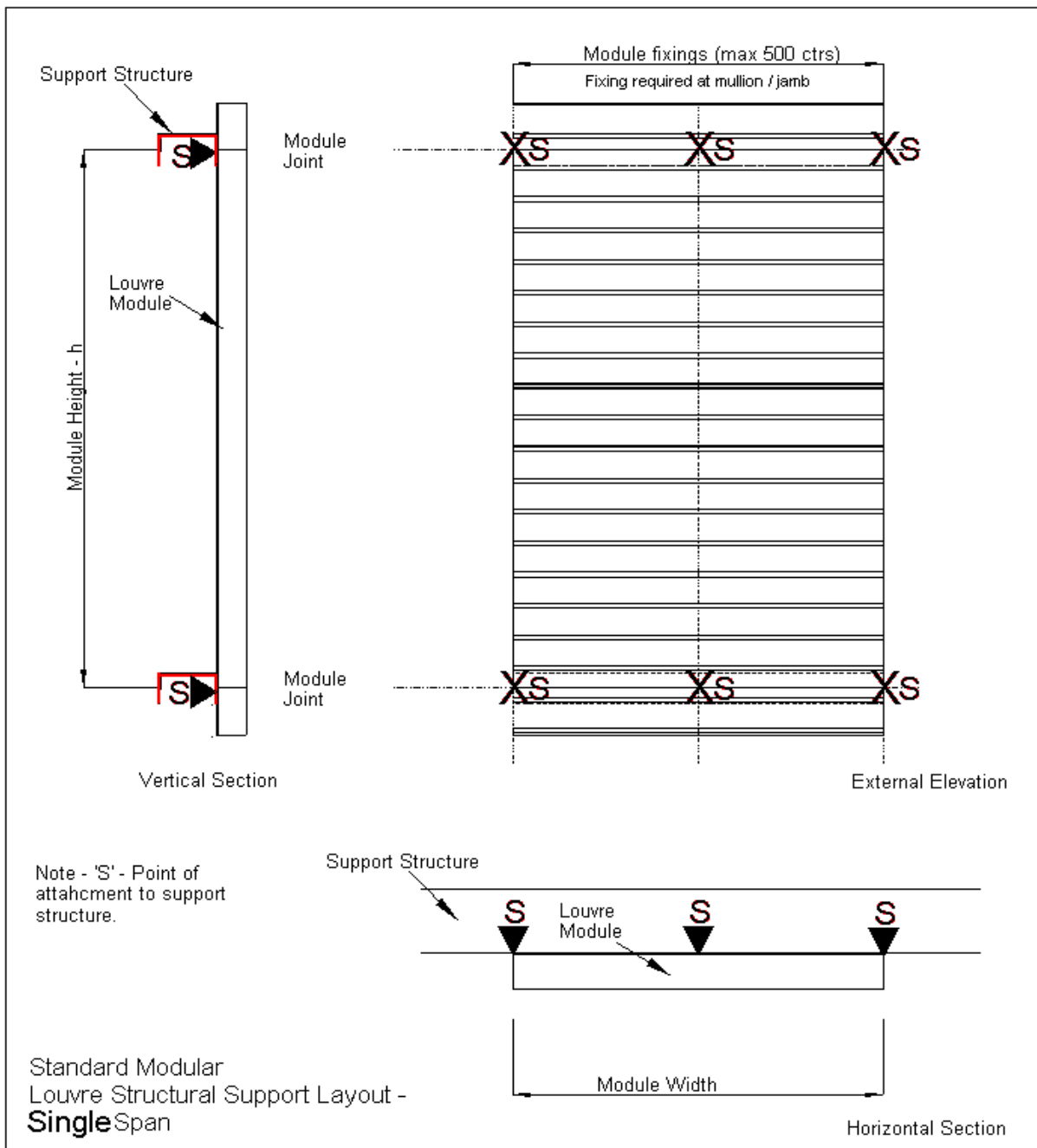

I value of jambs = 300000mm⁴

SINGLE PASS STD100						
Wind Load	0.5 KN/m ²	1 KN/m ²	1.5 KN/m ²	2 KN/m ²	2.5 KN/m ²	3 KN/m ²
Max Unsupported Ht	3000 mm	2550 mm	2250 mm	2050 mm	1875 mm	1775 mm

Table I.4. STD60 Double Pass Modular Single Span

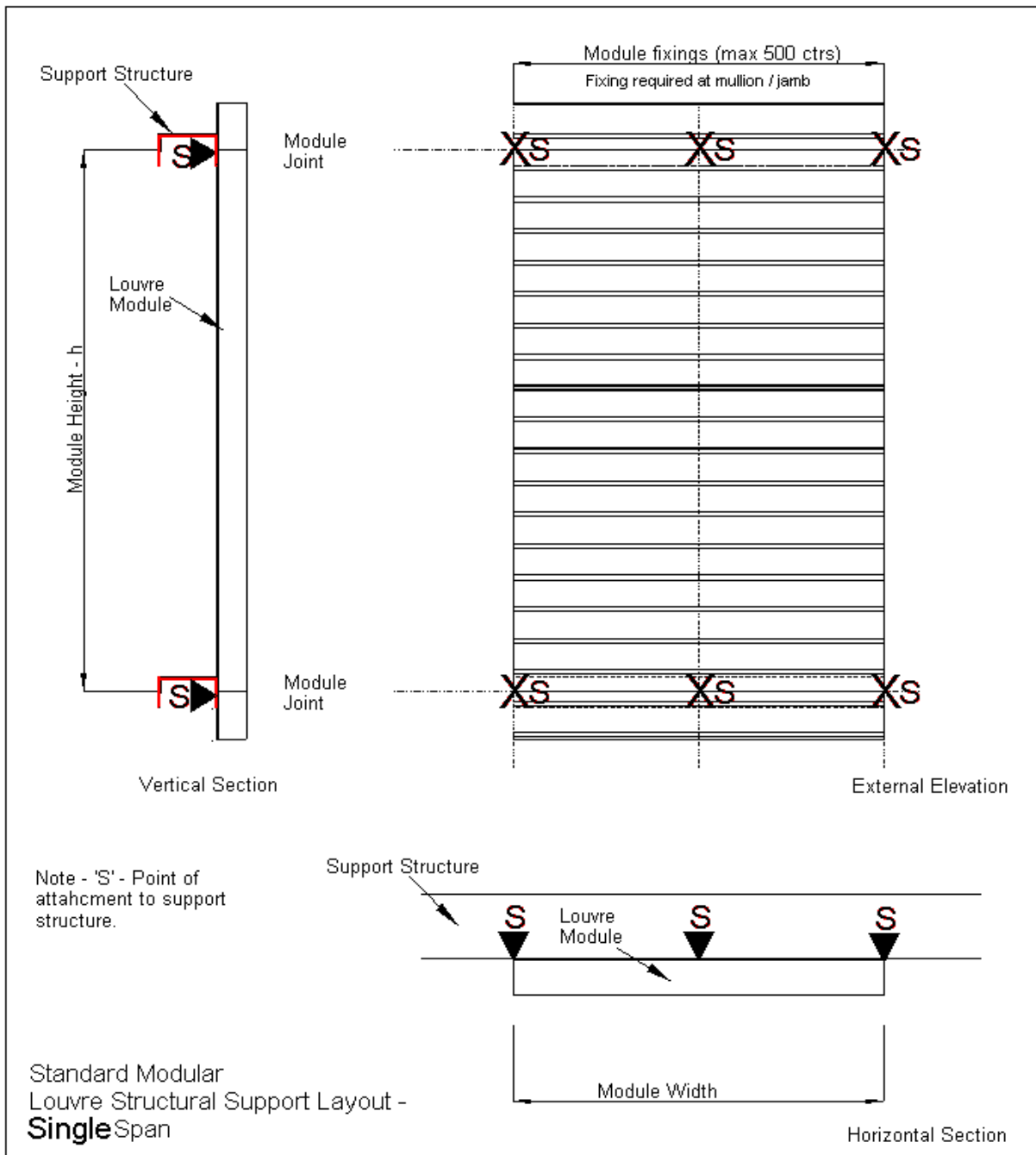

I value of jambs = 440000 mm⁴

DOUBLE PASS STD60						
Wind Load	0.5 KN/m ²	1 KN/m ²	1.5 KN/m ²	2 KN/m ²	2.5 KN/m ²	3 KN/m ²
Max Unsupported Ht	3000 mm	2950 mm	2550 mm	2300 mm	2150 mm	2050 mm

Table I.5. STD80 Double Pass Modular Single Span

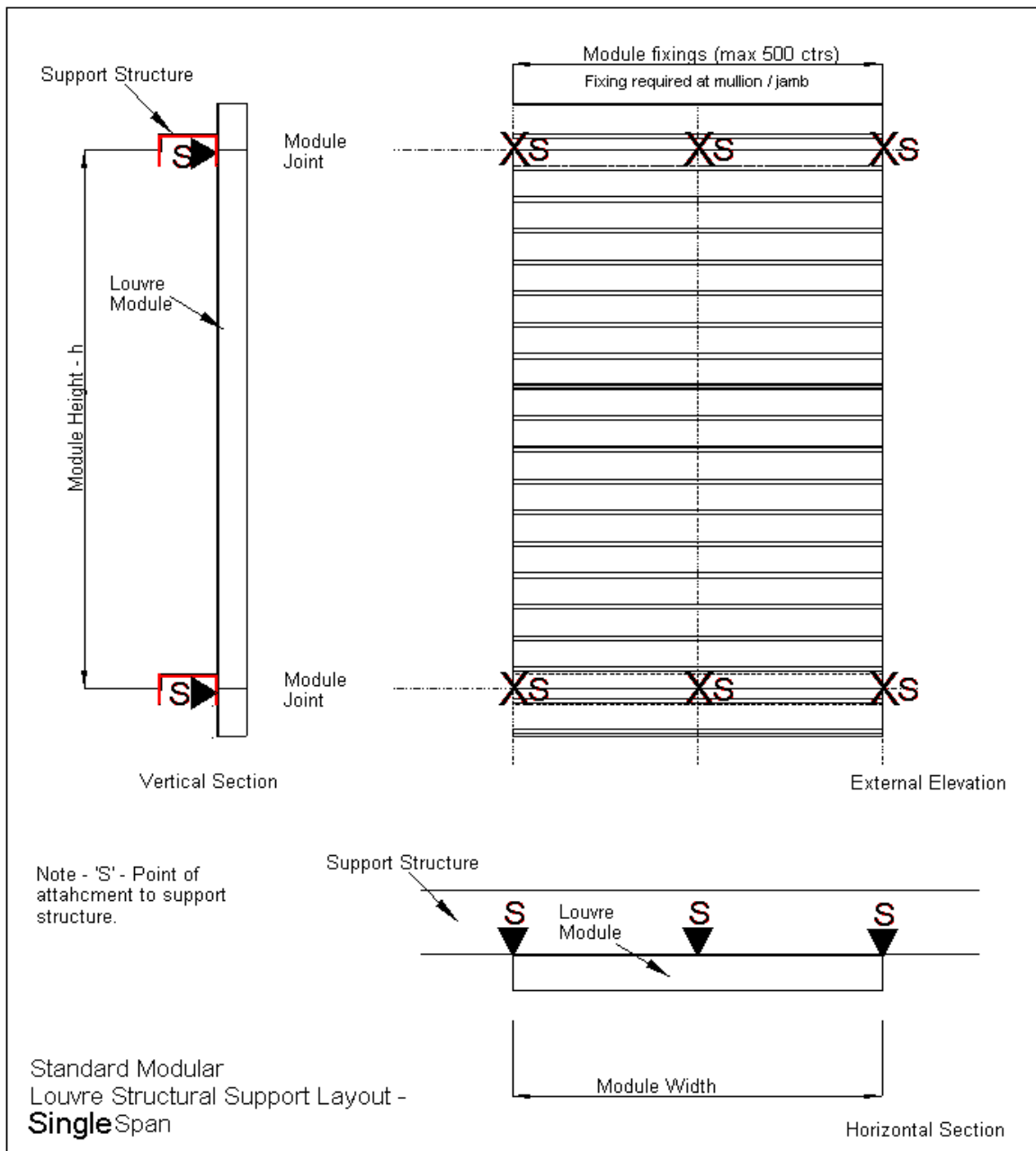

I value of jambs = 1700000 mm⁴

DOUBLE PASS STD80						
Wind Load	0.5 KN/m ²	1 KN/m ²	1.5 KN/m ²	2 KN/m ²	2.5 KN/m ²	3 KN/m ²
Max Unsupported Ht	3000 mm	3000 mm	3000 mm	3000 mm	3000 mm	3000 mm

Table I.6. STD100 Double Pass Modular Single Span

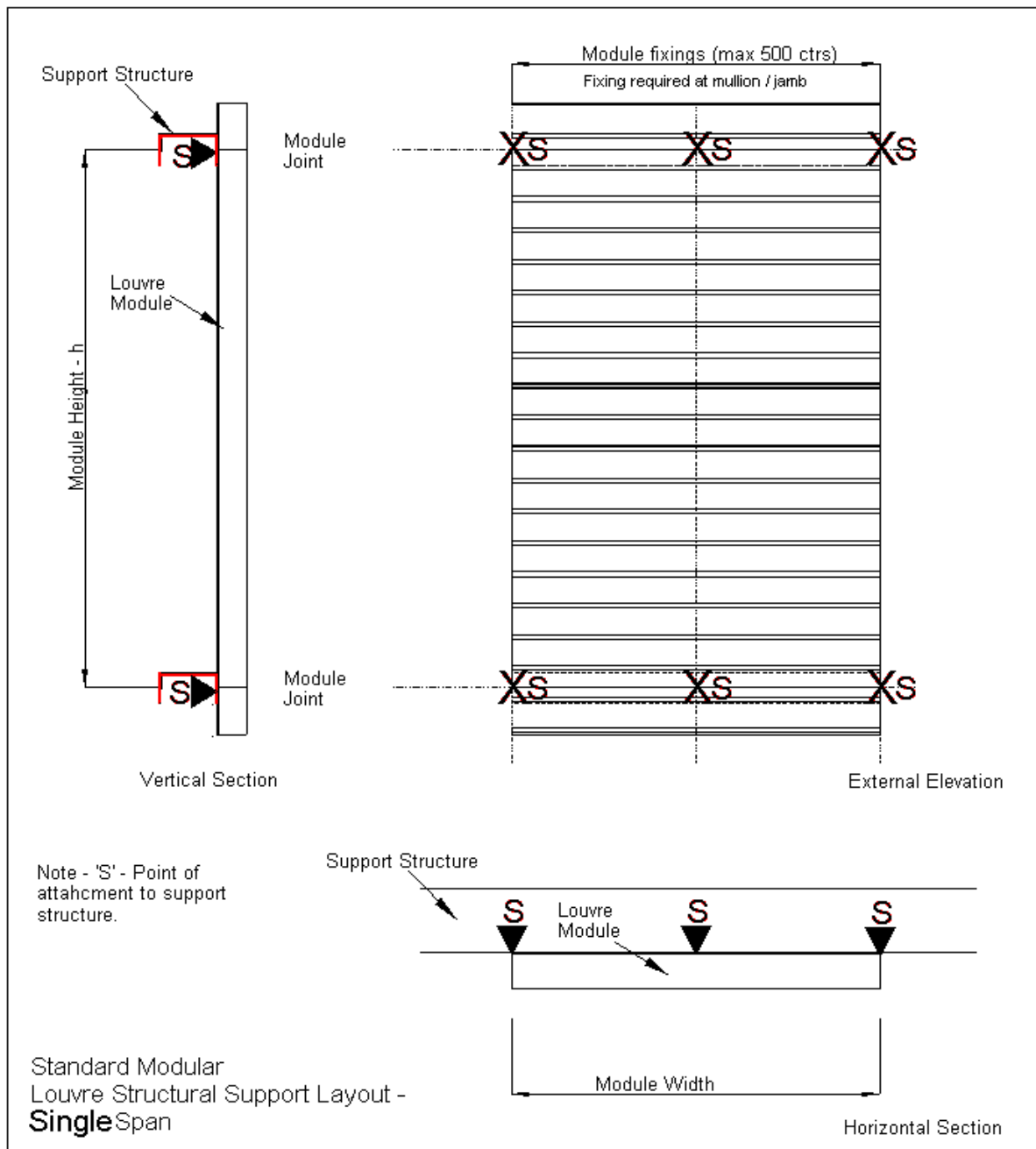

I value of jambs = 620000 mm⁴

DOUBLE PASS STD100						
Wind Load	0.5 KN/m ²	1 KN/m ²	1.5 KN/m ²	2 KN/m ²	2.5 KN/m ²	3 KN/m ²
Max Unsupported Ht	3000 mm	3000mm	2875 mm	2675 mm	2400 mm	2275 mm

Table I.7 STD60 Triple Pass Modular Single Span

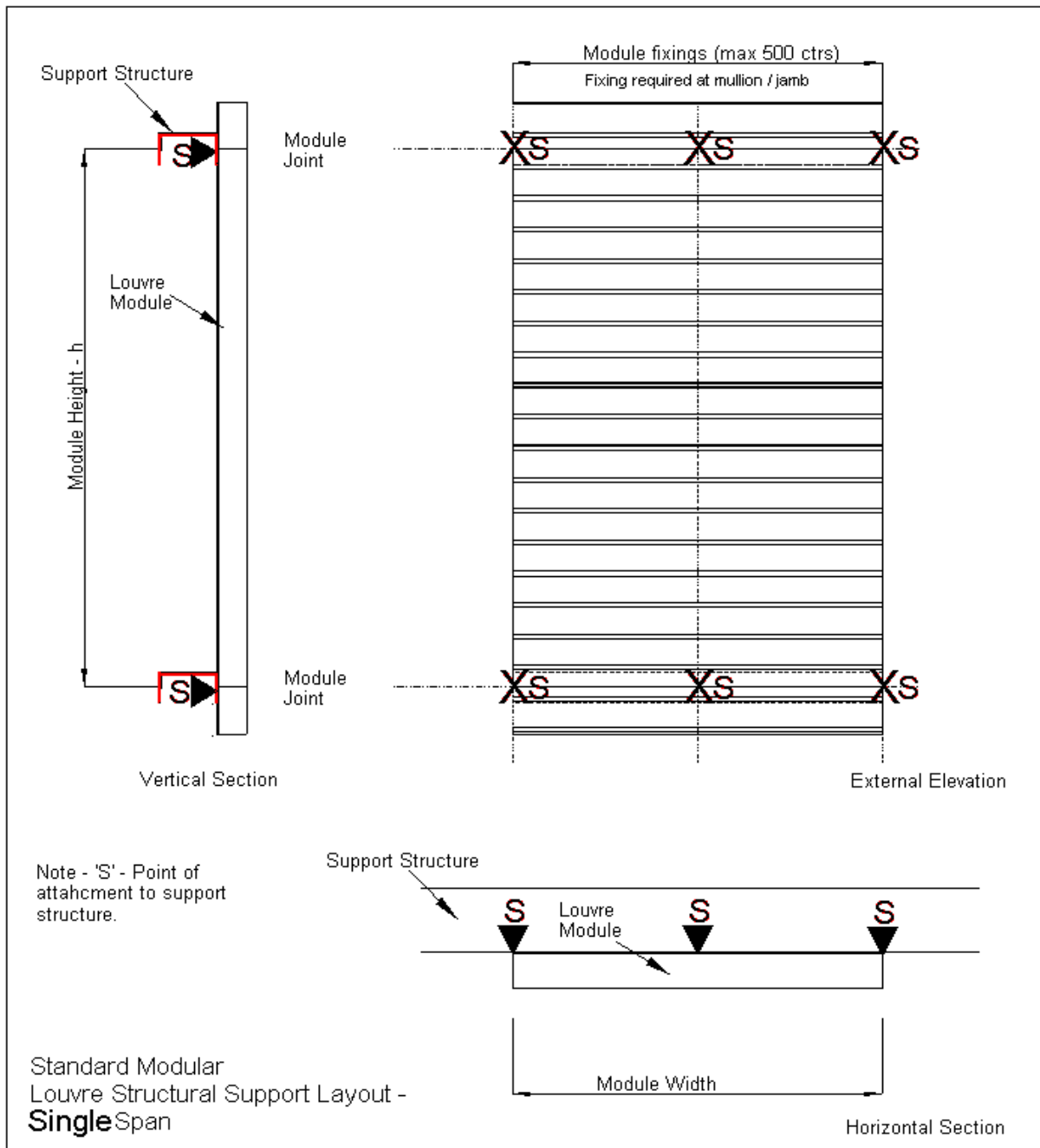

I value of jambs = 1200000 mm⁴

TRIPLE PASS STD60						
Wind Load	0.5 KN/m ²	1 KN/m ²	1.5 KN/m ²	2 KN/m ²	2.5 KN/m ²	3 KN/m ²
Max Unsupported Ht	3000 mm	3000 mm	3000 mm	3000 mm	3000 mm	2875 mm

Table I.8 STD80 Triple Pass Modular Single Span

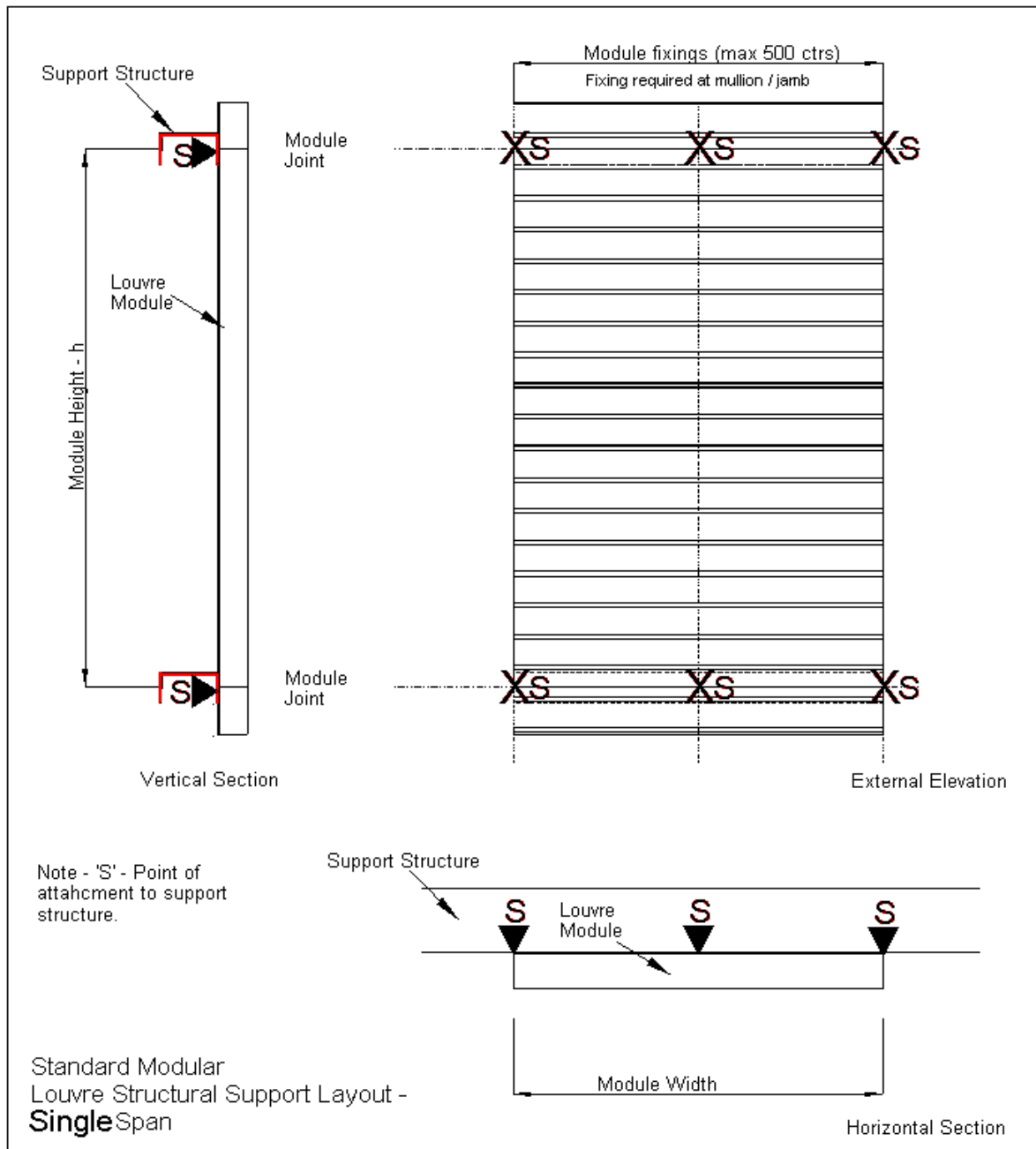

I value of jambs = 2200000 mm⁴

TRIPLE PASS STD80						
Wind Load	0.5 KN/m ²	1.0 KN/m ²	1.5 KN/m ²	2 KN/m ²	2.5 KN/m ²	3 KN/m ²
Max Unsupported Ht	3000 mm	3000 mm	3000 mm	3000 mm	3000 mm	3000 mm

Table I.9 STD100 Triple Pass Modular Single Span

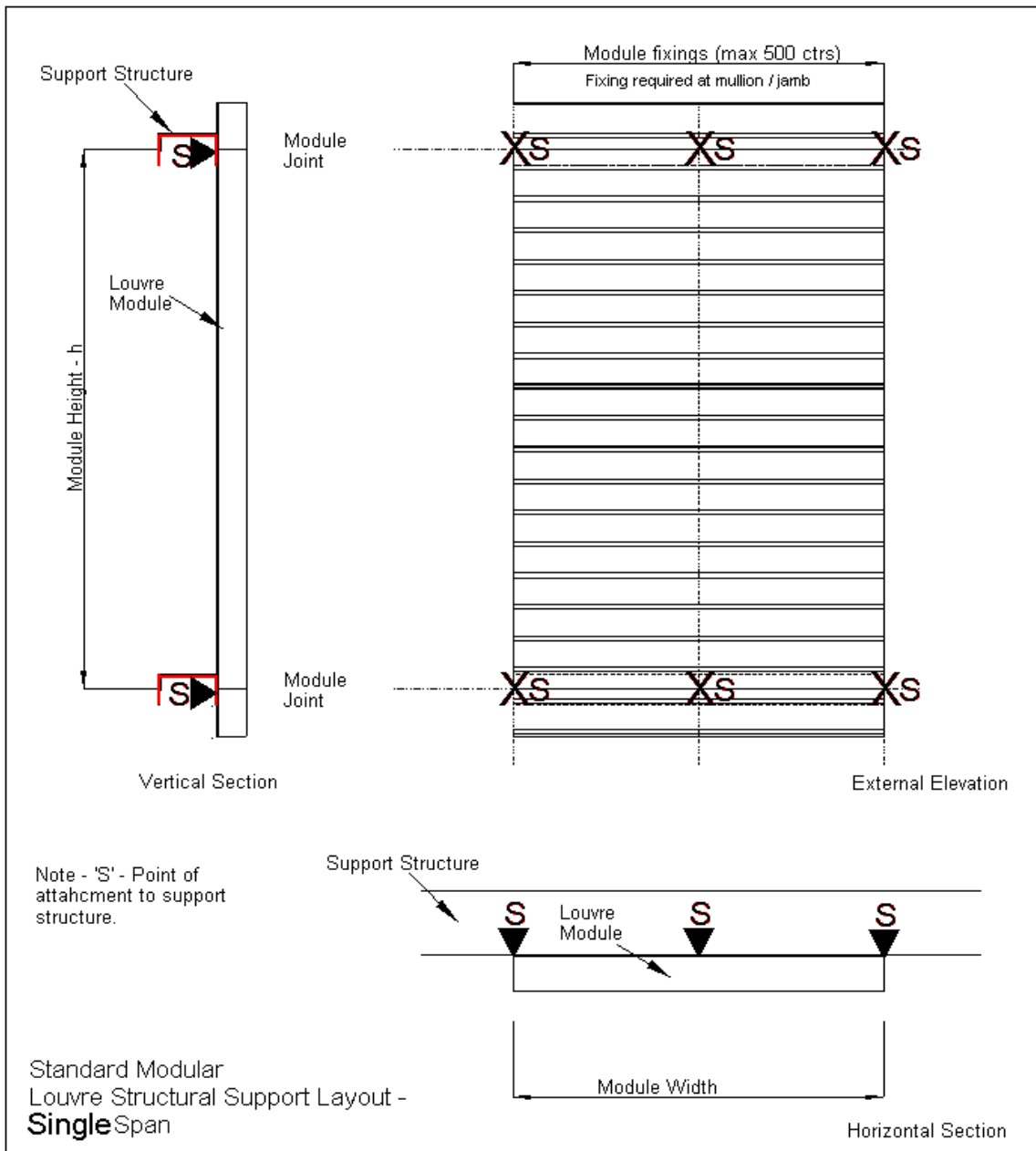

I value of jambs = 1700000 mm⁴

TRIPLE PASS STD100						
Wind Load	0.5 KN/m ²	1 KN/m ²	1.5 KN/m ²	2 KN/m ²	2.5 KN/m ²	3 KN/m ²
Max Unsupported Ht	3000 mm	3000 mm	3000 mm	3000 mm	3000 mm	3000 mm

Continuous Louvre Structural Analysis

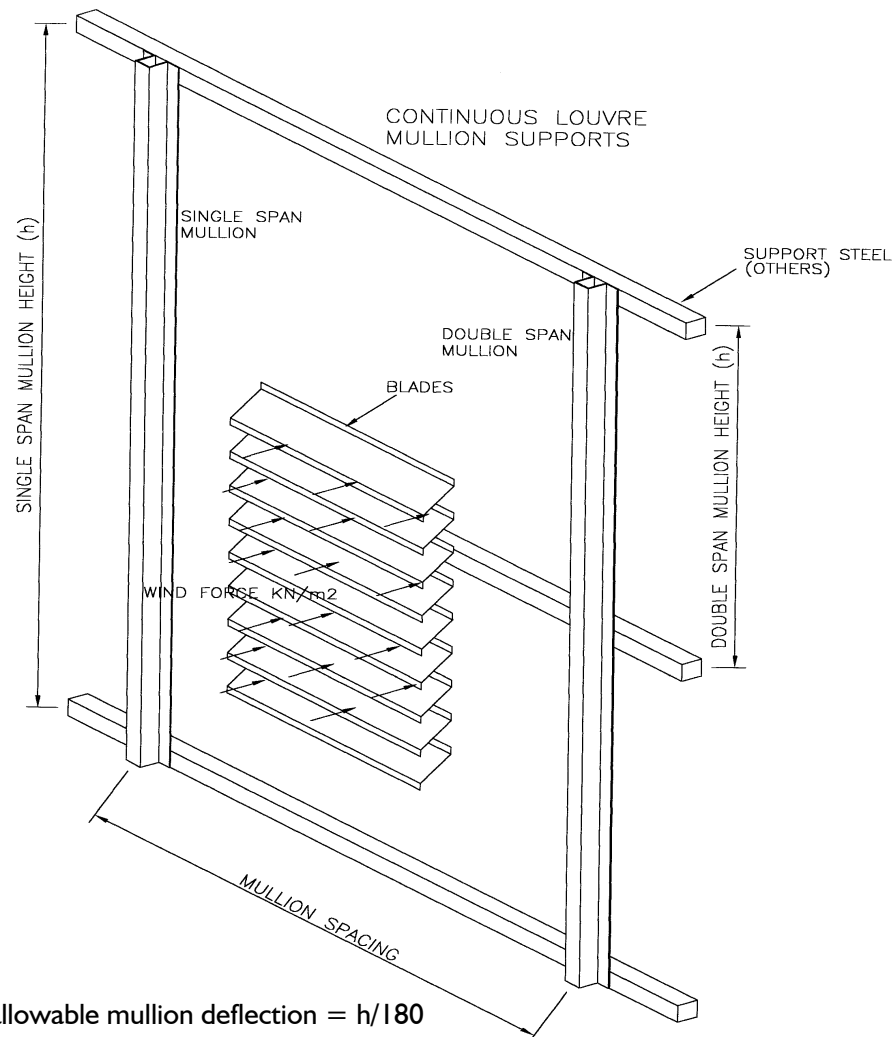

Figure 3

Assumption – Maximum allowable mullion deflection = $h/180$

For A Single Span Mullion -

$$\text{Maximum mullion length (h)} = (E \times I / (0.7 \times 180 \times (5/384) \times w \times \text{wind}))^{1/3}$$

For A Double Span Mullion -

$$\text{Maximum mullion length (h)} = (E \times I / (0.7 \times 180 \times (1/185) \times w \times \text{wind}))^{1/3}$$

Where,

Proportion of blade subjected to load = 0.7

$E = 65500 \text{ N/mm}^2$ (for aluminium)

$w =$ mullion spacing mm (max 1250mm)

$\text{wind} =$ wind load KN/m^2

$I =$ Moment of inertia of mullion ($1.5 \times 10^5 \text{ mm}^4$ for 1.5mm pressed mullion and $2.02 \times 10^5 \text{ mm}^4$ for extruded mullion)

To determine louvre dimensions use the tables attached with appropriate wind load. If louvre is blanked multiply the wind load by 1.42.



List of Load / Span Tables

Table I.10 STD60/80/100 Continuous Single Pass Single Span – 1.5mm Pressed Mullion

Table I.11 STD60/80/100 Continuous Double Pass Single Span – 1.5mm Pressed Mullion

Table I.12 STD60/80/100 Continuous Triple Pass Single Span – 1.5mm Pressed Mullion

Table I.13 STD60/80/100 Continuous Single Pass Single Span – Extruded Universal Mullion

Table I.14 STD60/80/100 Continuous Double Pass – Extruded Aluminium Mullion

Table I.10 STD60/80/100 Continuous Single Pass 1.5mm Pressed Mullion

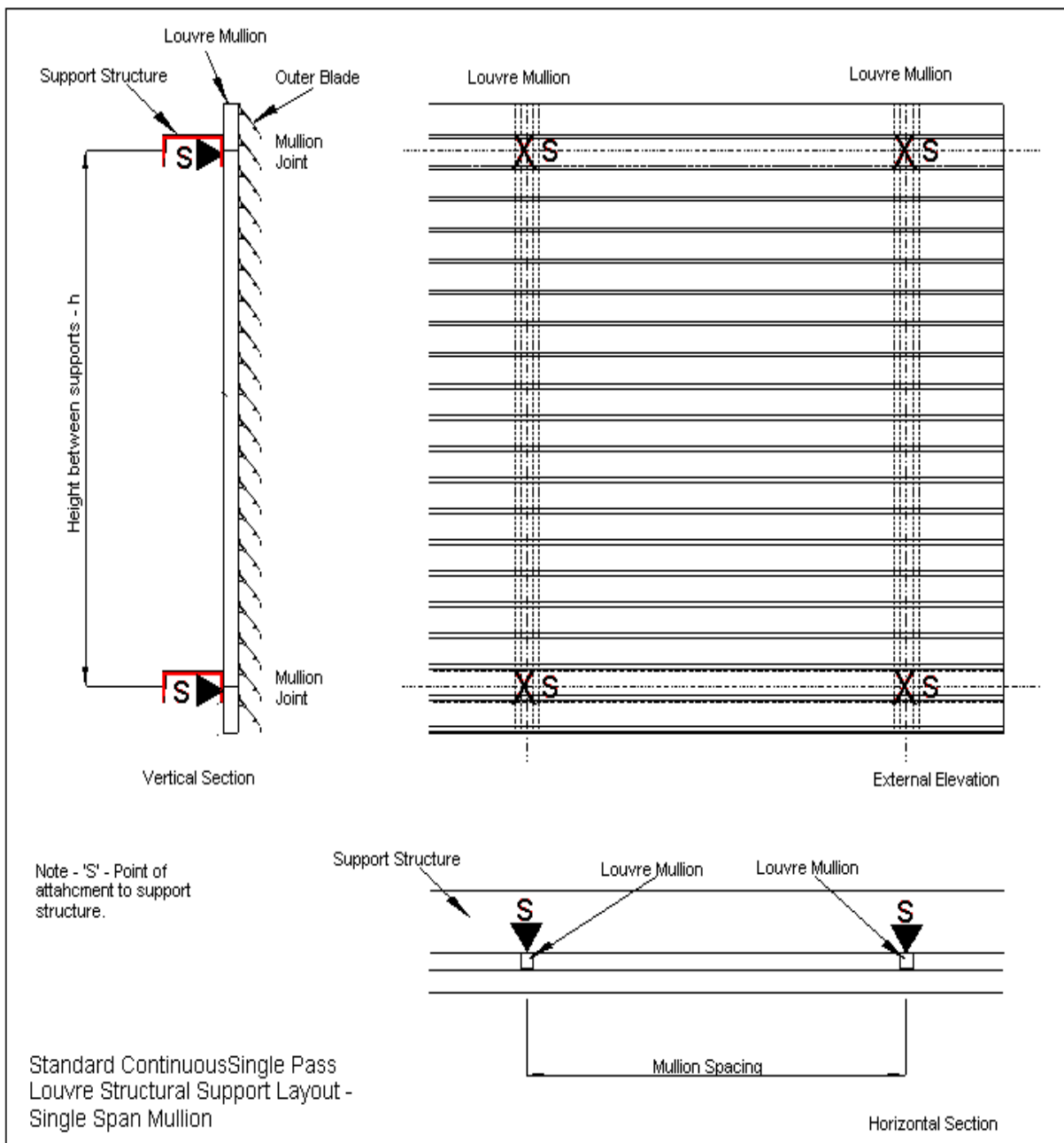

1.5mm PRESSED MULLION						
Wind Load	0.5 KN/m ²	1 KN/m ²	1.5 KN/m ²	2 KN/m ²	2.5 KN/m ²	3 KN/m ²
Max Unsupported Ht	2100mm	1680mm	1470mm	1350mm	1240mm	1170mm

Table I.11 STD60/80/100 Continuous Double Pass- 1.5mm Pressed Mullion

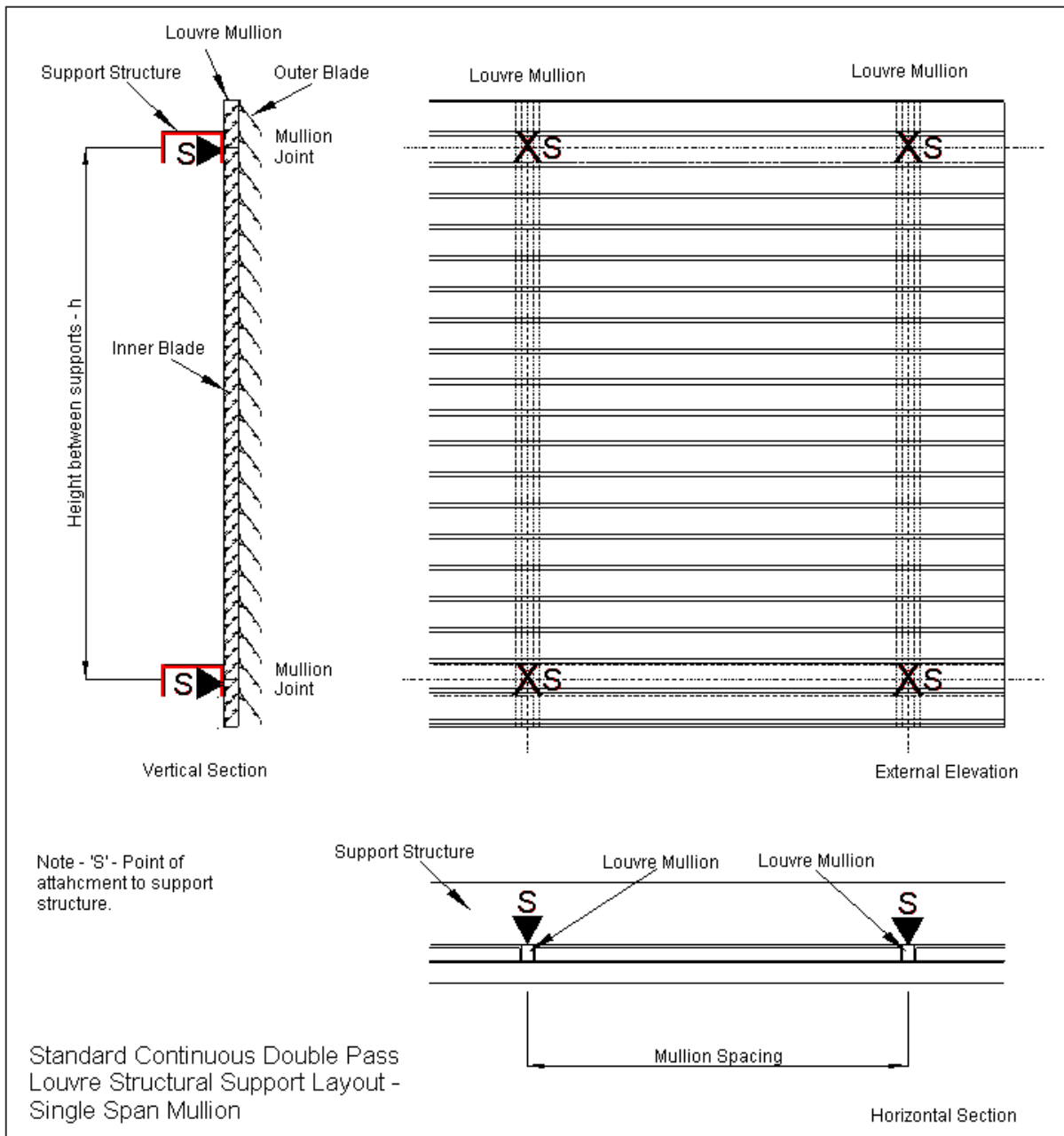

1.5mm PRESSED MULLION						
Wind Load	0.5 KN/m ²	1 KN/m ²	1.5 KN/m ²	2 KN/m ²	2.5 KN/m ²	3 KN/m ²
Max Unsupported Ht	2100mm	1680mm	1470mm	1350mm	1240mm	1170mm

Table I.12 STD60/80/100 Continuous Triple Pass – 1.5mm Pressed Mullion

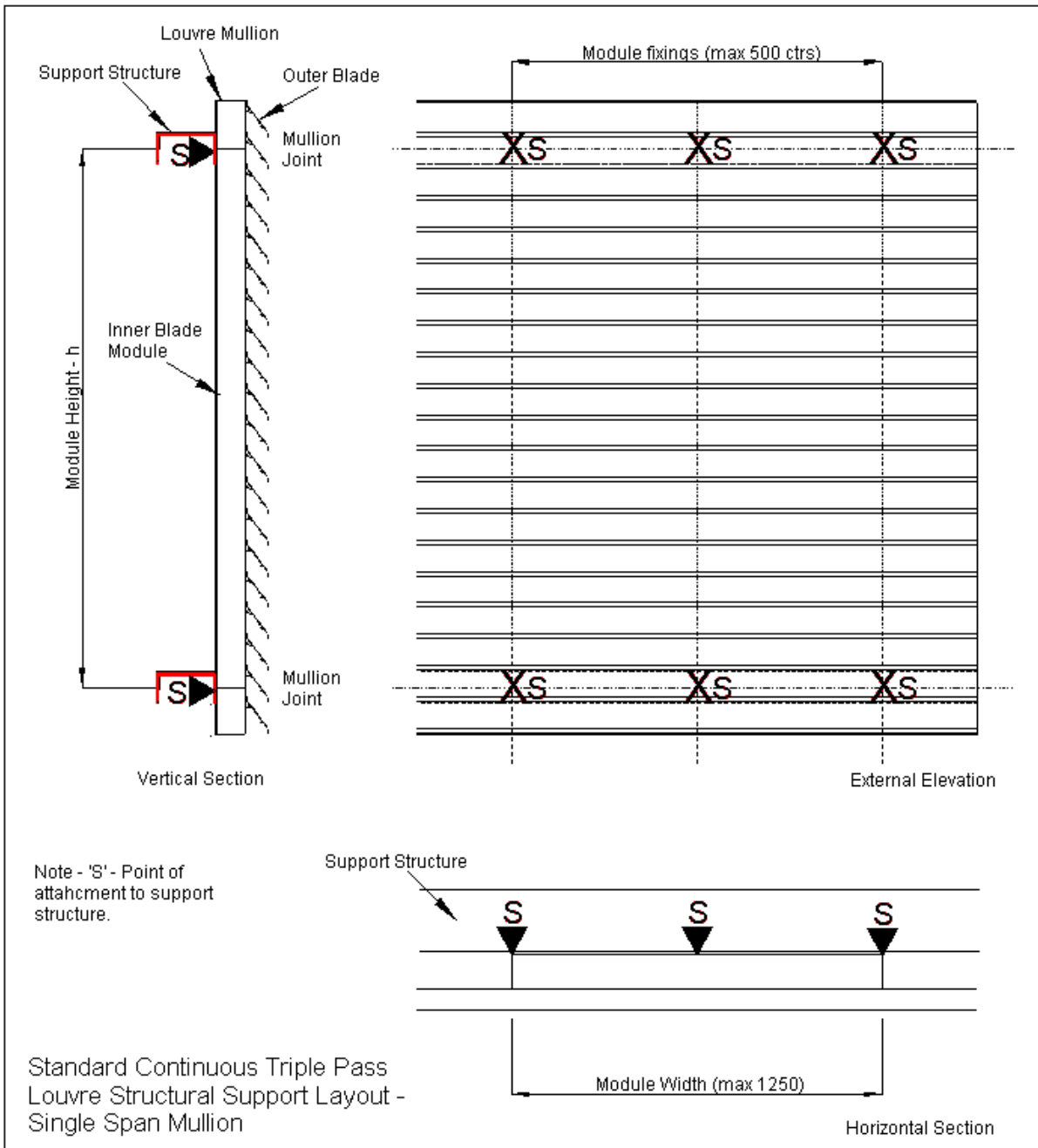

TRIPLE PASS CONTINUOUS						
Wind Load	0.5 KN/m ²	1 KN/m ²	1.5 KN/m ²	2 KN/m ²	2.5 KN/m ²	3 KN/m ²
Max Unsupported Ht	3000mm	2699mm	2357mm	2142mm	1988mm	1871mm

Table I.13 STD60/80/100 Continuous Single Pass - Extruded Universal Mullion

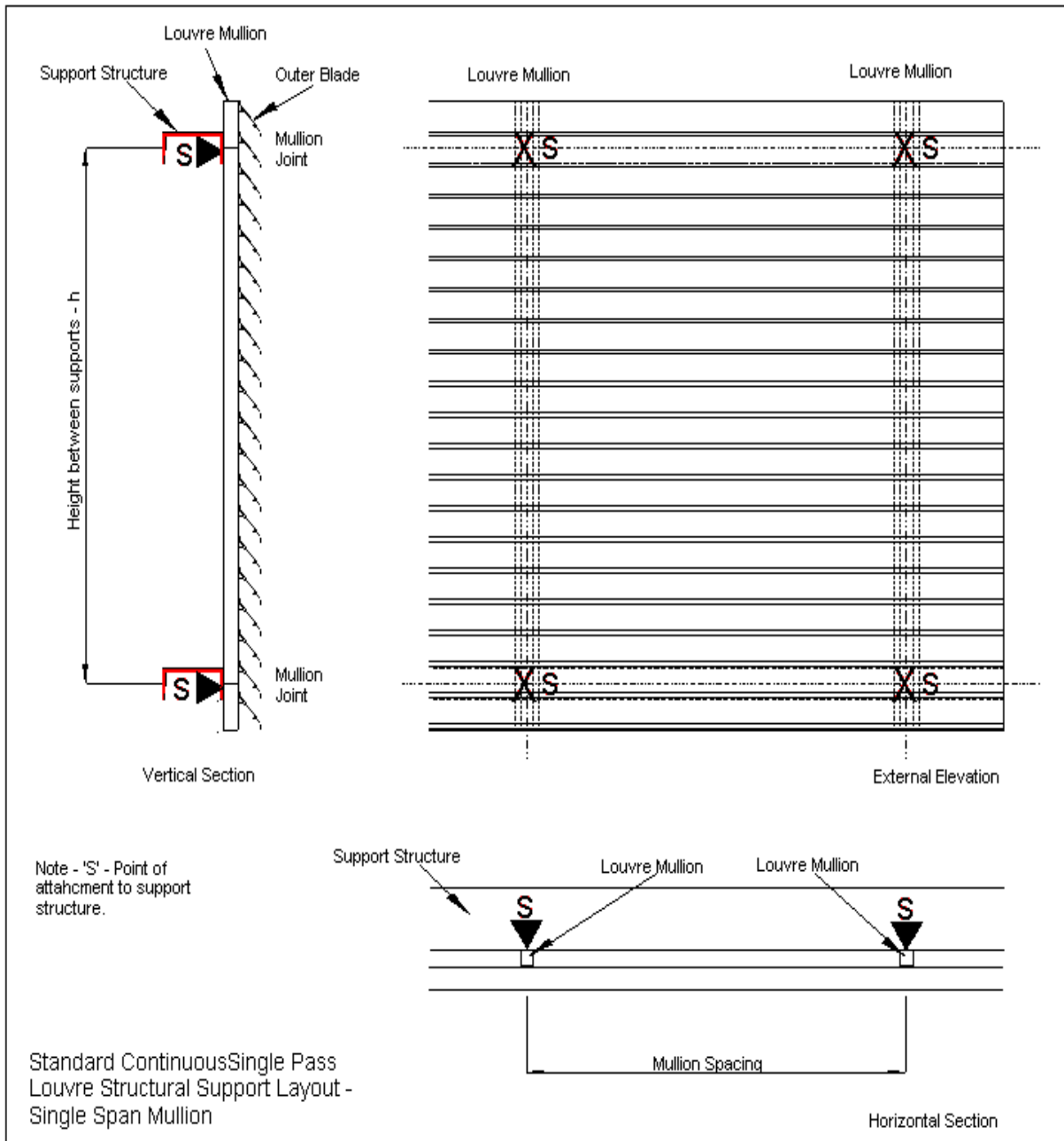

EXTRUDED MULLION						
Wind Load	0.5 KN/m ²	1 KN/m ²	1.5 KN/m ²	2 KN/m ²	2.5 KN/m ²	3 KN/m ²
Max Unsupported Ht	2300mm	1860mm	1630mm	1480mm	1380mm	1290mm

Table I.14 STD 60/80/100 Continuous Double Pass Extruded Aluminium Mullion

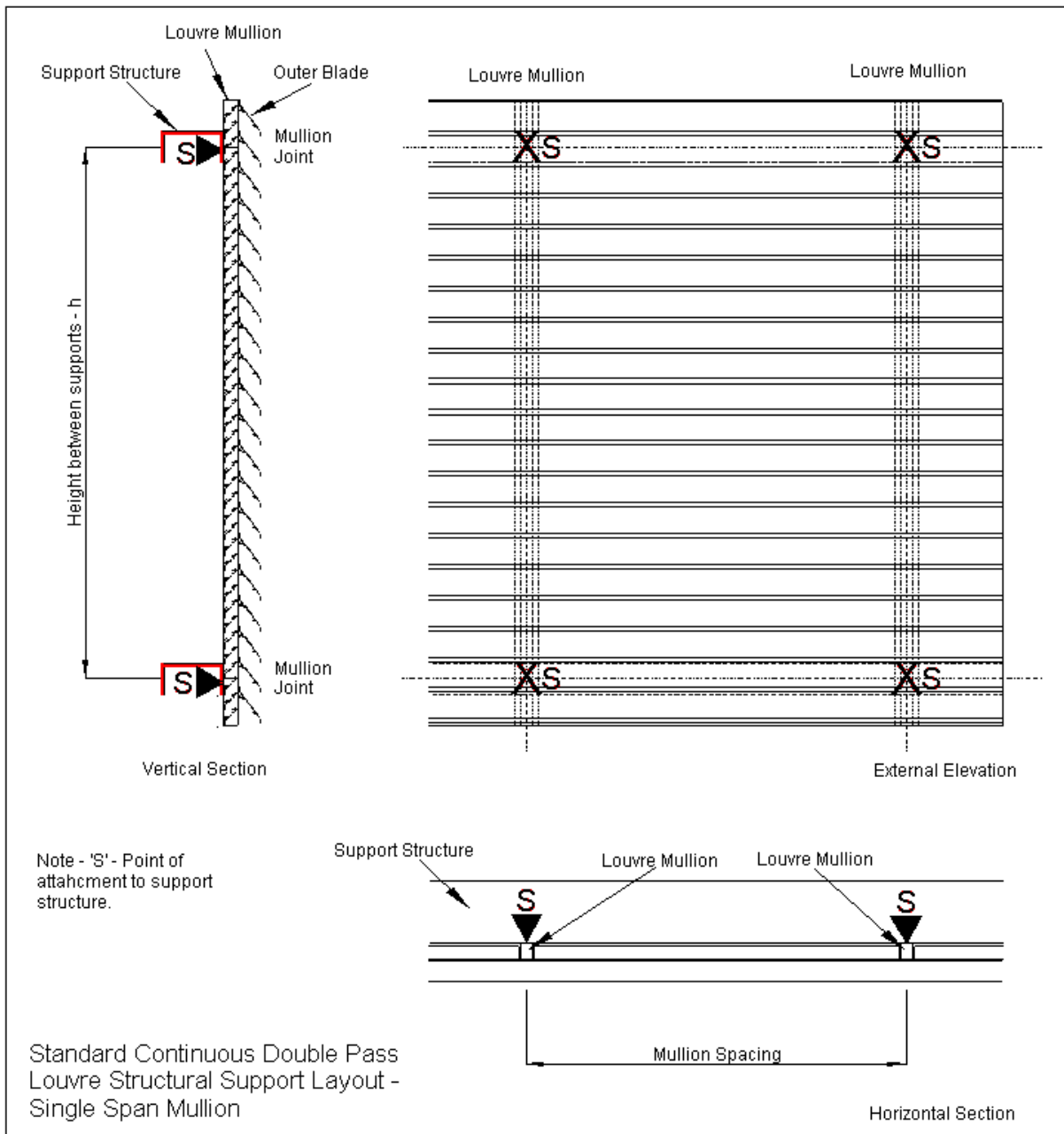

EXTRUDED MULLION						
Wind Load	0.5 KN/m ²	1 KN/m ²	1.5 KN/m ²	2 KN/m ²	2.5 KN/m ²	3 KN/m ²
Max Unsupported Ht	2300mm	1860mm	1630mm	1480mm	1380mm	1290mm